



GEMKHANA 2024

COMPETITION SCHEDULE AND CONDITIONS

GEMKHANA 2024 – COMPETITION SCHEDULE AND CONDITIONS

GENERAL CONDITIONS

1. This is a Level 3 Competition and will be judged in accordance with the rules and definitions of the ***Competitor & Judging Manual for Lapidary and Allied Competitions Issue no. 8 April 2015***. (referred to in this Schedule as the Manual), unless otherwise stated in this Schedule.
2. All competitors are advised to familiarise themselves with all the “Conditions for Competitors” in the Manual (particularly pages 5 to 13)
3. Competitors should be aware of, or check their eligibility to enter a Novice or Intermediate Division either by: -
 - Reading Section B4 of the manual (pages 6 & 7) relating to Competition Divisions, or by
 - checking the updated results list on the AFLACA website (<http://aflaca.org.au>)

4. Enquiries, correspondence and ALL POSTAL ENTRIES relating to this Competition should be directed to:

GEMKHANA Competition Committee 2024

P.O. Box 188

Orange NSW

2800

Phone enquiries to Kathy Selwood: 0437 917 074

5. Maximum number of entries allowed is two (2) per person per section except for Showcase Sections where only one entry per person is allowed.
6. It is the Competitor’s responsibility to ensure that their entries are entered in the correct section and that the sections are correctly marked on the Entry Form. If in doubt ring the Competition Committee.

However, the Competition Committee may transfer an entry into another section if they are of the opinion that it has obviously been enter in the incorrect section.

7. Entry Fees: - \$1.00 per entry for the first 10 entries, thereafter free.
(Payable by cheque or money order to Gem & Lapidary Council of NSW Inc)
8. All entries not being collected in person at the GEMKHANA must be accompanied by the **cost of return** post or **pre-paid post bag** included with the entry form (see Page 13).
9. While every care will be taken, the GEMKHANA 2024 Committee will not accept any responsibility for the loss or damage of any entries or exhibits that may occur in transit or whilst in the possession of the GEMKHANA 2024 committee.
10. Competitors and exhibitors are responsible for the insurance of their entries or exhibits while in transit, and whilst in the possession of the GEMKHANA 2024 Committee.

11. How to enter the Competition – Sections 1 to 4, 8 to 13 and 18 to 26

- a. Package up your entries to cushion them from damage whilst in transit – also see SC3.
- b. Fill out an official entry form – see page 13 of this Schedule.
- c. If you want acknowledgement of receipt of your entries, include a stamped, self-addressed envelope.
- d. Organise a cheque or money order payable to the Gem & Lapidary Council of NSW Inc for the entry fees (and return express postage if you are not collecting the entries in person at the GEMKHANA.
- e. Submit your Entries + Entry Form + All fees to the Competition Committee. This can either be:
 - By Express post to
GEMKHANA 2024 Committee
P.O. Box 188 Orange
NSW 2800

They must be received by Friday 23rd August 2024

- By hand delivery to
Kathy Selwood,
At Parramatta/Holroyd Lapidary
Club, Fullagar Rd,
Wentworthville

Between 12 noon and 2.00pm on Wednesday 28th August 2024

NOTE that late entries will not be eligible for competition and will be returned.

12. How to Enter the Competition – Sections 5, 16, 17, 29, 32, 34 and showcases

- a. Send your Entry Form and All Entry Fees to **arrive by Friday 23rd August 2024** to:-
GEMKHANA 2024 Competition Committee
P.O. Box 188 Orange
NSW 2800
- b. Hand deliver the entries to the Competition committee in the Competition Hall at the
GEMKHANA 2024 VENUE between **1pm and 5pm on Friday 27th September 2024**
- c. Note that entries in Sections 29, 32 & 34 must be set up and ready in the Exhibition Hall by **5.00pm Friday 27th September 2024**

13. Judging, Judging Sheets and Entry Pickup

- a. Entries in Sections 1 to 4, 8 to 13, 18 to 26 will be judged prior to the GEMKHANA.
- b. Entries in Sections 5, 16, 17, 29, 32, and 34 will be judged at the GEMKHANA.
- c. Judging Sheets may be collected from the Competition Office between 10am and 12 noon on **Sunday 29th September 2024**
- d. Entries may be collected between 6pm and 7pm on **Sunday 29th September 2024**
- e. Entries not collected will be returned to the competitor in the manner specified on the entry form together with the applicable judging sheets.

14 SPECIAL CONDITIONS (SC)

SCI – Sizes and Tolerances

Where an entry does not conform to the size conditions in this Schedule or the Manual it will be ruled ineligible and not judged. Refer to section definitions in the Schedule and the Manual for allowable tolerances.

SC2 – Carving (Section 5)

Each entry must have a label which best describes the exhibit for the viewer's interest including the material used. These labels will not be judged.

SC3 - Facet Entries (Section 8 to 11)

- a. All chosen designs have either been previously used in competitions or have been successfully test cut using instructions given
- b. **ALL** Facets are **FLAT**, any entry with Concave or Curved facets (except Section 8A continuous girdle) will be disqualified and will NOT be judged.
- c. **Minimum size** is 6mm measured across shortest axis of outline shape at the girdle, or as indicated on design sheet.
- d. Each faceted stone must be entered in a display box and this box must contain a label which contains only the following details:
 - Section Number
 - Material used
 - Colour of material
 - Size

SC4 – Tumbled Stones (Section 12A)

Please read page 19 (D2.2) and page 55 (D12.1) of the Manual for definition of this section.

SC5 – Jewellery (Sections 18 – 26)

Competitors should carefully read Part E of the Manual in relation to all Jewellery Sections.

15 TROPHIES AND MEDALLIONS

1. Medallions and prize cards will be awarded for 1st, 2nd, and 3rd placed entries. Highly Commended will receive a prize card only.
2. At the Committee's discretion, where there are insufficient entries in a Novice or Intermediate Sections, a Special Award May be nominated and such an award will not exclude a competitor from entering the same section in future competitions.
3. To be eligible in winning a 'Dick Moppett Trophy: in faceting, entries must achieve a minimum of 70 points for Novice and 90 points for Open.
4. Annual Trophies may be awarded in the following categories: -

SPECIAL ONE-OFF TROPHIES

Donated by Gem & Lapidary Council of NSW

Section N-1A.3 Novice Standard Cabochon -C/S-Highest Score

Section O-13.1 Open Polished Face-Flat Surface-Highest Score

Section N-19A.2 Novice Cast Jewellery not intended to include
Lapidary, Fossil or Mineral Item/s-Highest Score

THE JOAN BALL TROPHIES

Section O-26B.1 Open Enamelled Jewellery without Mount
-Highest Score

Section O-17.1 Open Novelty Gemcraft-Highest Score

THE ALAN COULTON TROPHY

Section O-20A.1 Open Cast Jewellery using Natural Objects as Patterns
-Highest Score

5. Perpetual Trophies may be awarded for the following :-

THE BORIS NOVIC TROPHY

Section O-2A.1 The competitor with the highest score in Section O-2A.1 Double Standard Cabochon – C/S

THE DICK MOPPETT TROPHY – NOVICE

Sections N-8A.3 & N-9A.3 For the Novice competitor with the highest aggregate point for two (2) faceted stones - one shall be **STANDARD BRILLIANT** and the other a **STANDARD STEP CUT**. Note that each entry must achieve a minimum standard of **70 points**.

THE DICK MOPPETT TROPHY – OPEN

Sections O-8A.1 & O-9A.1 For the Open Competitor with the highest aggregate points for two (2) faceted stones – one shall be **STANDARD BRILLIANT** and the other a **STANDARD STEP CUT**. Note that each entry must achieve a minimum standard of **90 points**.

THE ARTHUR ROFFEY TROPHY for “BEST MINERAL IN SHOW”

(As selected by the donor)

THE FRANK LANDER TROPHY for MOST SUCCESSFUL COMPETITOR

Points are awarded as:- 1st place – 6 points 2nd place – 4 points 3rd place – 2 points .
Highly Commended = 1 point. Special Award – 6 points

THE FRANK HALL TROPHY for MOST SUCCESSFUL CLUB

Points awarded as:- 1st place – 6 points, 2nd place – 4 points, 3rd place – 2 points.
Highly commended – 1-point, Special award – 6 points. Entries within 75% of the winning entry's score – 1 point.

GEMKHANA 2024 – COMPEITION SCHEDULE AND CONDITIONS

Judging will be in accordance with the AFLACA Competition and Judging Manual Issue No. 8

O= Open I = Intermediate N = Novice J = Junior TR = Trophy

C/S = Craftsmanship A/A = Aesthetic Appeal SC = Special Condition Applies

Standard Cabochon – Must not pass through a 15mm hole (SCI)

O-1A.1	Standard Cabochon	C/S – Any Material	
I-1A.2	Standard Cabochon	C/S – Any Material	
N-1A.3	Standard Cabochon	C/S – Any Material	TR
J-1A.4	Standard Cabochon	C/S - Any Material	
O-1A.5	Standard Cabochon	A/A Tiger’s Eye	
I-1A.6	Standard Cabochon	A/A Tiger’s Eye	
N-1A.7	Standard Cabochon	A/A Tiger’s Eye	
J-1A.8	Standard Cabochon	A/A Tiger’s Eye	

Fancy Cabochon – Minimum Dimension to be not less than 30mm on the longest Dimension across the outline shape (SCI)

O-1B.1	Fancy Cabochon	C/S – Ribbonstone
I-1B.2	Fancy Cabochon	C/S – Ribbonstone
N-1B.3	Fancy Cabochon	C/S – Ribbonstone
J-1B.4	Fancy Cabochon	C/S – Any Material
O-1B.5	Fancy Cabochon	A/A – Any Material
I-1B.6	Fancy Cabochon	A/A – Any Material
N-1B.7	Fancy Cabochon	A/A – Any Material
J-1B.8	Fancy Cabochon	A/A – Any Material

Double Standard Cabochon - must not pass through a 15mm hole (SCI)

O-2A.1	Double Standard Cabochon	C/S – Any material	TR
I-2A.2	Double Standard Cabochon	C/S – Any material	
N-2A.3	Double Standard Cabochon	C/S – Any material	

Double Fancy Cabochon – Must not pass through a 15 mm hole (SCI)

O-2B.1	Double Fancy Cabochon	C/S – Any Material
I-2B.2	Double Fancy Cabochon	C/S – Any Material
N-2B.3	Double Fancy Cabochon	C/S – Any Material

Freeform – Must not pass through 15mm hole (SCI)

O-3.1	Freeform	C/S – Any Material
I-3.2	Freeform	C/S – Any Material
N-3.3	Freeform	C/S – Any Material
J-3.4	Freeform	C/S – Any Material

Freeform – Must not pass through 10mm hole (SCI)

O-3.5	Freeform	C/S – Opal Solid
N-3.6	Freeform	C/S – Opal Solid

Opal Doublets- Must not pass through 10mm hole (SCI)

O-4A	Opal Doublet – Flat Top
O-4B	Opal Doublet – Domed Top

Carving – Hardness under 4 – Minimum size 50mm on the longest dimension (excluding base or mount) – Maximum size 300mm (including base of mount) (SCI and SC2)

O-5A.1	Carving – 3 dimensional
N-5A.2	Carving – 3 dimensional

Carving – Any Hardness – Minimum size 50mm on the longest dimension (excluding base or mount) Maximum size 300mm (including base or mount) (SC1 and SC2)

O-5B.1	Carving – in relief
N-5B.2	Carving – in relief

Carving – any hardness – minimum size 50 mm on the longest dimension (excluding base or mount) – maximum size 300mm (including base or mount) (SCI and SC2)

O-5E.1	Carving not otherwise specified in Groups 5A to 5D
N-5E.2	Carving not otherwise specified in Groups 5A to 5D

Facet Cuts – Minimum size 6mm on shortest axis of outline shape – Groups 8, 9, 10 and 11 – (SC1 and SC3)

O-8A.1 I-8A.2 N-8A.3 Standard Round Brilliant with Continuous Girdle **Colourless Quartz TR**

O-9A.1 I-9A.2 N-9A.3 Standard Oblong Step Cut with Cut corners **Coloured Quartz TR**

O-10.1	Modified Standard Cut – Markeasy	MM Coloured Corundum
I-10.2	Modified Standard Cut – The Gold Octagon	MM Coloured Corundum
N-10.3	Modified Standard Cut – Australian Star	MM Coloured Corundum
O-11.1	Fancy Cut – Sirius	Coloured Cubic Zirconia
I-11.2	Fancy Cut – Brilliant Fire	Coloured Cubic Zirconia
N-11.3	Fancy Cut – Delta Apex Variation	Coloured Cubic Zirconia

Tumbled Stones – must not be able to pass through a 15mm diameter hole (SC4)

O-12A.1	Tumbled Stones – Preformed Shape	Group of 3- different materials
N-12A.2	Tumbled Stones – Preformed Shape	Group of 3 – Any material
O-12B.1	Tumbled Stones- Natural Shape	Group of 3- Any material
N-12B.2	Tumbled Stones- Natural Shape	Group of 3- Any Material

Polished Face – Minimum size 50mm across shortest axis – Maximum size 300mm on any dimension

O-13.1	Polished Flat Surface	C/S	TR
N-13.2	Polished Flat Surface	C/S	
J-13.3	Polished Flat Surface	C/S	
O-14.1	Polished Curved Surface	A/A	
N-14.2	Polished Curved Surface	A/A	
J-14.3	Polished Curved Surface	A/A	

Gem Trees - must fit in 300mm cube but must not fit in a 150mm cube (SC1)

O-16.1	Gem Tree
N-16.2	Gem Tree

Novelty Gemcraft – Minimum size 50mm on the longest dimension excluding base (SC1)

O-17.1	Novelty Gem craft	TR
N-17.2	Novelty Gem craft	

Hand Fabricated and Wire Wrapped Jewellery (SC5)

- O-18A.1 Hand Fabricated Jewellery **NOT** intended to include Lapidary, Fossil or Mineral Specimen (s)
- I-18A.2 Hand Fabricated Jewellery – **NOT** intended to include Lapidary, Fossil or Mineral Specimen (s)
- N-18A.3 Hand Fabricated Jewellery – **NOT** intended to include Lapidary, Fossil or Mineral Specimen (s)
- O-18B.1 Hand Fabricated Jewellery-- **WITH** lapidary Item (s) cut and set by entrant
- I-18B.2 Hand Fabricated Jewellery – **WITH** lapidary item(s) cut and set by entrant
- N-18B.3 Hand Fabricated Jewellery – **WITH** lapidary item(s) cut and set by entrant
- O-18D.1 Hand Fabricated Jewellery **WITH** Commercial Lapidary Item (s) set by entrant
- N-18D.2 Hand Fabricated Jewellery – **WITH** Commercial Lapidary item (s) set by entrant.
- O-18E.1 Wire Wrapped Jewellery- **WITH** Lapidary, Fossil or Mineral Items(s) prepared/ set by entrant
- N-18E.2 Wire Wrapped Jewellery **WITH** Lapidary. Fossil or Mineral Item (s) prepared/ set by entrant

Cast Jewellery – using Patterns, mould or Dies MADE BY ENTRANT (SC5)

- O-19A.1 Cast Jewellery **NOT** intended to include Lapidary Fossil or Mineral Item(s)
- N-19A.2 Cast Jewellery **NOT** intended to include Lapidary Fossil or Mineral Item(s) **TR**

Metal Clay Jewellery – using Patterns, Moulds or Dies MADE BY ENTRANT(SC5)

- O-19E.1 Metal Clay Jewellery **NOT** intended to include Lapidary, Fossil or Mineral Item(s)
- N-19E.2 Metal Clay Jewellery **NOT** intended to include Lapidary Fossil or Mineral Item(s)

Cast Jewellery – using Natural Objects as Patterns (SC5)

- O-20A.1 Cast Jewellery **NOT** intended to include Lapidary Fossil or Mineral Item(s) **TR**
- N-20A.2 Cast Jewellery **NOT** intended to include Lapidary Fossil or Mineral Item(s)

Metal Clay Jewellery – using natural Object as Patterns (SC5)

- O-20E.1 Metal Clay Jewellery **NOT** intended to include lapidary, fossils or minerals
- N-20E.2 Metal Clay Jewellery **NOT** intended to include lapidary, fossils or minerals

Cast Jewellery – using Commercial Wax Models or Patterns (SC5)

- O-21A.1 Cast Jewellery **NOT** intended to include Lapidary Fossil or Mineral Item(s)
N-21A.2 Cast Jewellery **NOT** intended to include Lapidary Fossil or Mineral Item(s)

Metal Clay Jewellery – using Commercial Wax Models or Patterns (SC5)

- O-21G.1 Metal Clay Jewellery **WITH** Commercial Lapidary Item(s) set by Entrant
N-21G.2 Metal Clay Jewellery **WITH** Commercial Lapidary Item(s) set by Entrant

Combined Jewellery – with Lapidary Items cut and set by Entrant (SC5)

- O-23B.1 Combined Jewellery **WITH** lapidary items cut & set by Entrant

Enamelled Jewellery in Hand Fabricated Setting (SC5)

- O-24A.1 Enamelled Jewellery in hand fabricated setting
N-24A.2 Enamelled Jewellery in hand fabricated setting

Commercial Mount Jewellery (SC5)

- O-25.1 Commercial Mount Jewellery **WITH** Lapidary item(s) cut and set by entrant
I-25.2 Commercial Mount Jewellery **WITH** Lapidary item(s) cut and set by entrant
N-25.3 Commercial Mount Jewellery **WITH** Lapidary item(s) cut and set by entrant

Enamelling Sections (SC5)

- O-26A.1 Enamelled Jewellery in Commercial Mount
N-26A.2 Enamelled Jewellery in Commercial Mount
O-26B.1 Enamelled Jewellery without Mount **TR**
N-26B.2 Enamelled Jewellery without Mount
O-26C.1 Enamelling – non-Jewellery
N-26C.2 Enamelling – non-Jewellery

Showcases

O-29B.1 Showcase General – LIT

Fossils

O-32A.1 Fossils Non-Display – Any Locality

N-32A.2 Fossils Non-Display Any locality

O-32B.1 Fossils Non-Display Group of 3

N-32B.2 Fossils Non-Display Group of 3

Minerals

O-34A.1 Mineral Non-Display Single Specimen Any Locality Cabinet Size

N-34A.2 Mineral Non-Display Single Specimen Any Locality Cabinet Size

O-34A-3 Mineral Non-Display Single Specimen Any Locality Miniature

N.34A.4 Mineral Non-Display Single Specimen Any Locality Miniature

O-34B.1 Mineral Non -Display Group of Three Any Locality Thumbnail

N-34B.2 Mineral Non -Display Group of Three Any Locality Thumbnail

GEMKHANA 2024 OFFICIAL COMPETITION FORM

Mail to: The Competition Committee

PO Box 188, Orange NSW 2800

Postal Entries: All Entry Forms and fees- must be **RECEIVED BY THE COMMITTEE** by Friday 23rd August 2024

Hand delivered: Entries-Wednesday 28th August 2024 (12 noon to 2.00pm) at Parramatta/Holroyd Lapidary

Club **COMPETITOR DETAILS** Name:

Email:

Address

State: Postcode..... Personal Contact No

Full Club Details:

For Juniors Only, Date of Birth:/...../.....(NB: Must be under 16 at 23rd August 2024)

ENTRY SUMMARY AND FEES (Cheques made payable to Gem and Lapidary Council of NSW Inc)

No of Entries: Are entries to be returned by mail? (Circle) Yes/No

Entry Fees-\$1.00 per entry for first ten entries, thereafter free Amount \$.....

Return Postage- Registered \$.....

Total Amount Enclosed \$.....

Signature of Competitor:

ENTRIES BY SECTION- Postal (by Friday 23/08/24 and Drop off (Wednesday 28/08/24									
Section No	Entries (1or2)	Section No	Entries (1or2)	Section No	Entries (1or2)	Section No	Entries (1or2)	Section No	Entries (1or2)
O-1A.1		I-1A.2		N-1A.3		J-1A.4		O-1A.5	
I-1A.6		N-1A.7		J-1A.8		O-1B.1		I-1B.2	
N-1B.3		J-1B.4		O-1B.5		I-1B.6		N-1B.7	
J-1B.8		O-2A.1		I-2A.2		N-2A.3		O-2B.1	
I-2B.2		N-2B.3		O-3.1		I-3.2		N-3.3	
J-3.4		O-3.5		N-3.6		O-4A		O-4B	
O-8A.1		I-8A.2		N-8A.3		O-9A.1		I-9A.2	
N-9A.3		O-10.1		I-10.2		N-10.3		O-11.1	
I-11.2		N-11.3							
O-12A.1		N-12A.2		O-12B.1		N-12B.2			
O.13.1		N-13.2		J-13.3		O-14.1		N-14.2	
J-14.3		O-18A.1		I-18A.2		N-18A.3		O-18B.1	
I-18B.2		N-18B.3		O-18D.1		N-18D.2		O-18E.1	
N-18E.2		O-19A.1		N-19A.2		O-19E.1		N-19E.2	
O-20A.1		N-20A.2		O-20E.1		N-20E.2		O-21A.1	
N-21A.2		O-21G.1		N-21G.2		O-23B.1		O-24A.1	
N-24A.2		O-25.1		I-25.2		N-25.3		O-26A.1	
N-26A.2		O-26B.1		N-26B.2		O-26C.1		N-26C.2	

ENTRIES BY SECTIONS- Delivered and Setup by Entrant at GEMKHANA (Friday 27/09/24)									
Section No	Entries 1or2	Section No	Entries 1or2	Section No	Entries 1or2	Section No	Entries 1or2	Section No	Entries 1or2
O-5A.1		N-5A.2		O-5B.1		N-5B.2		O-5E.1	
N-5E.2		O-16.1		N-16.2		O-17.1		N-17.2	
O-29B.1		O-32A.1		N-32A.2		O-32B.1		N-32B.2	
O-34A.1		N-34A.2		O-34A.3		N-34A.4		O-34B.1	
N-34B.2									

2024 GEMKHANA

Section: O-8A.1, I-8A.2, N-8A.3, Standard Round Brilliant with Continuous Girdle

Material: Colourless Quartz

Facets: 57 + 1 girdle =58 (Crown=33 Pavilion=24)

Meets: 41 (Crown =24 Pavilion=17)

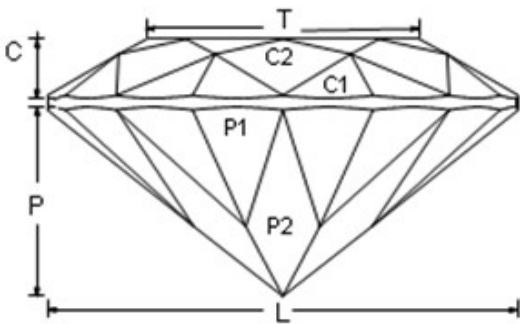
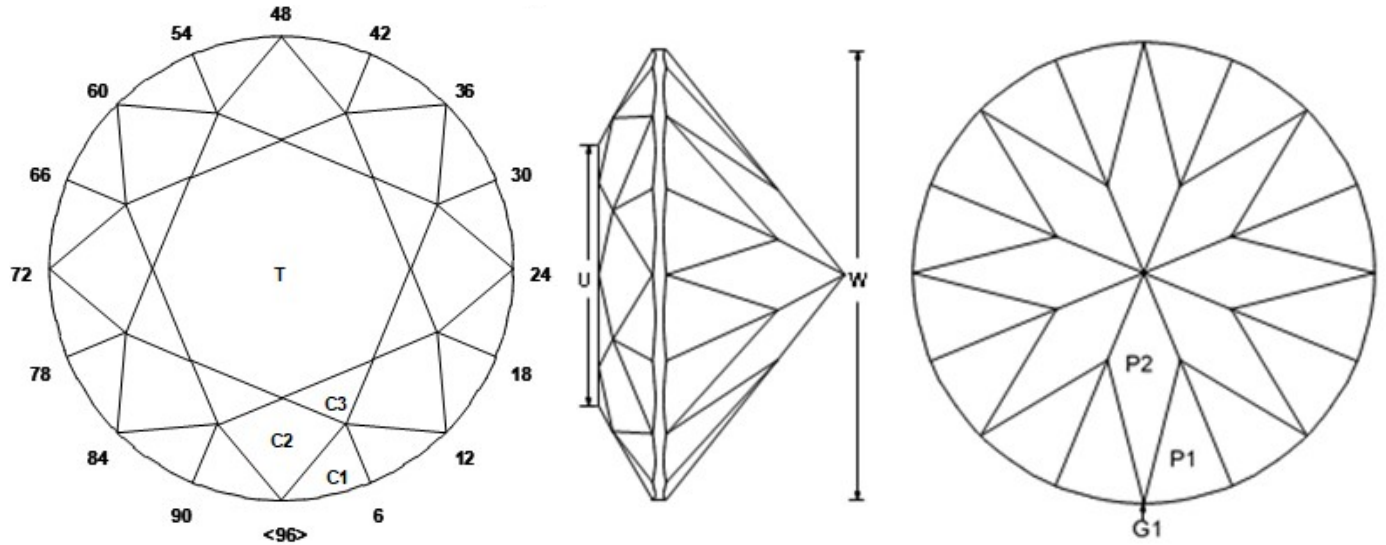

Standard Brilliant with Continuous Girdle

Angles for R.I. = 1.54
 57 + 1 girdle = 58 facets
 8-fold, mirror-image symmetry
 96 index
 $L/W = 1.000$ $T/W = 0.602$ $U/W = 0.602$
 $P/W = 0.435$ $C/W = 0.139$
 $Vol. /W^3 = 0.206$

PAVILION

P1	43.00°	03-09-15-21-27-33-39-45-	Cut to TCP
		51-57-63-69-75-81-87-93	
G1	90.00°	Rolled Girdle	Set size
P2	41.00°	96-12-24-36-48-60-72-84	Form PCP, meet P1, G1

CROWN

C1	42.00°	03-09-15-21-27-33-39-45-	Set girdle thickness
		51-57-63-69-75-81-87-93	
C2	35.00°	96-12-24-36-48-60-72-84	Cut to meet C1, G1
C3	20.00°	06-18-30-42-54-66-78-90	Cut to meet C1, C2
T	0.00°	Table	Cut to meet C2, C3

2024 GEMKHANA

Section: O-9A.1, I-9A.2, N-9A.3, Standard Oblong Step Cut with Cut Corners

Material: Coloured Quartz

Facets: 45 + 8 girdles = 53 (Crown=25 Pavilion=20)

Meets: 44 (Crown =24 Pavilion=20)

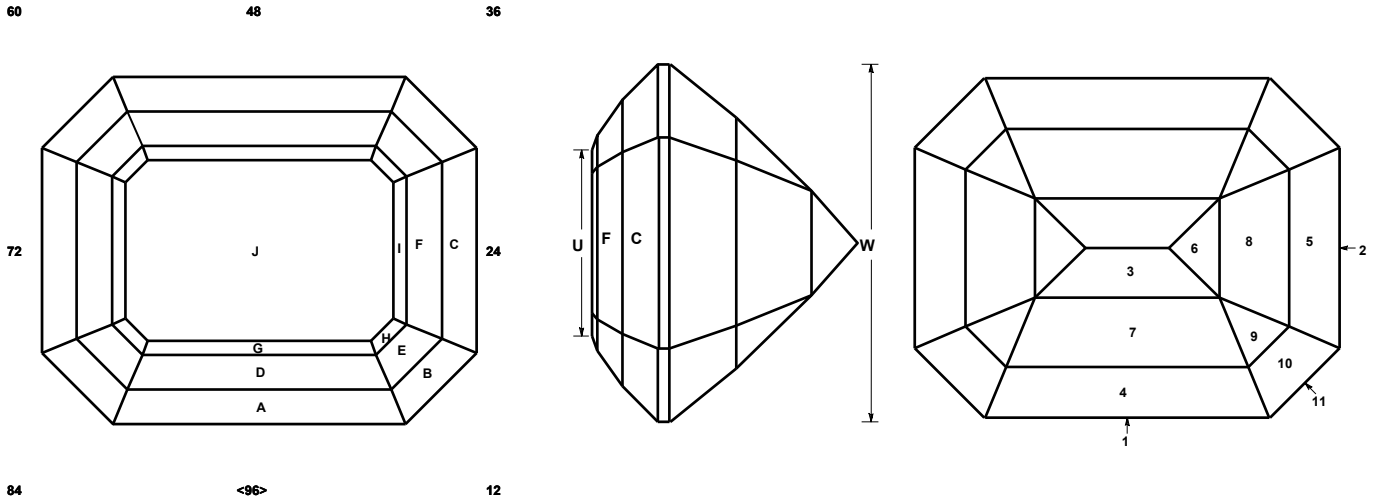

Standard Oblong Step Cut with Cut Corners

Anon

Angles for R.I. = 1.540

45 + 8 girdles = 53 facets

2-fold, mirror-image symmetry

96 index

L/W = 1.250 T/W = 0.768 U/W = 0.522

P/W = 0.525 C/W = 0.187

Vol./W³ = 0.439

PAVILION

1	90.00°	96-48	Set width
2	90.00°	24-72	Set Length
3	41.00°	96-48	Cut to centreline
4	51.02°	96-48	Estimate depth
5	51.02°	24-72	Level girdle
6	41.00°	24-72	Meet 3, 4
7	45.99°	96-48	Estimate depth
8	45.99°	24-72	Meet 7
9	45.99°	12-36-60-84	Meet 3, 6, 7, 8
10	51.02°	12-36-60-84	Meet 4, 7, 9
11	90.00°	12-36-60-84	Level girdle

CROWN

A	45.00°	96-48	Set girdle thickness
B	45.00°	12-36-60-84	Level girdle
C	45.00°	24-72	Level girdle
D	35.13°	96-48	Estimate
E	35.13°	12-36-60-84	Level tier
F	35.13°	24-72	Level tier
G	21.71°	96-48	Estimate
H	21.71°	12-36-60-84	Level tier
I	21.71°	24-72	Level tier
J	0.00°	Table	Estimate G

2024 GEMKHANA

Section: O-10.1 Markeasy

Material: Any Coloured MM Corundum

Facets: 55 + 16 girdles =71 (Crown=33 Pavilion=22)

Meets: 55 (Crown =32 Pavilion=23)

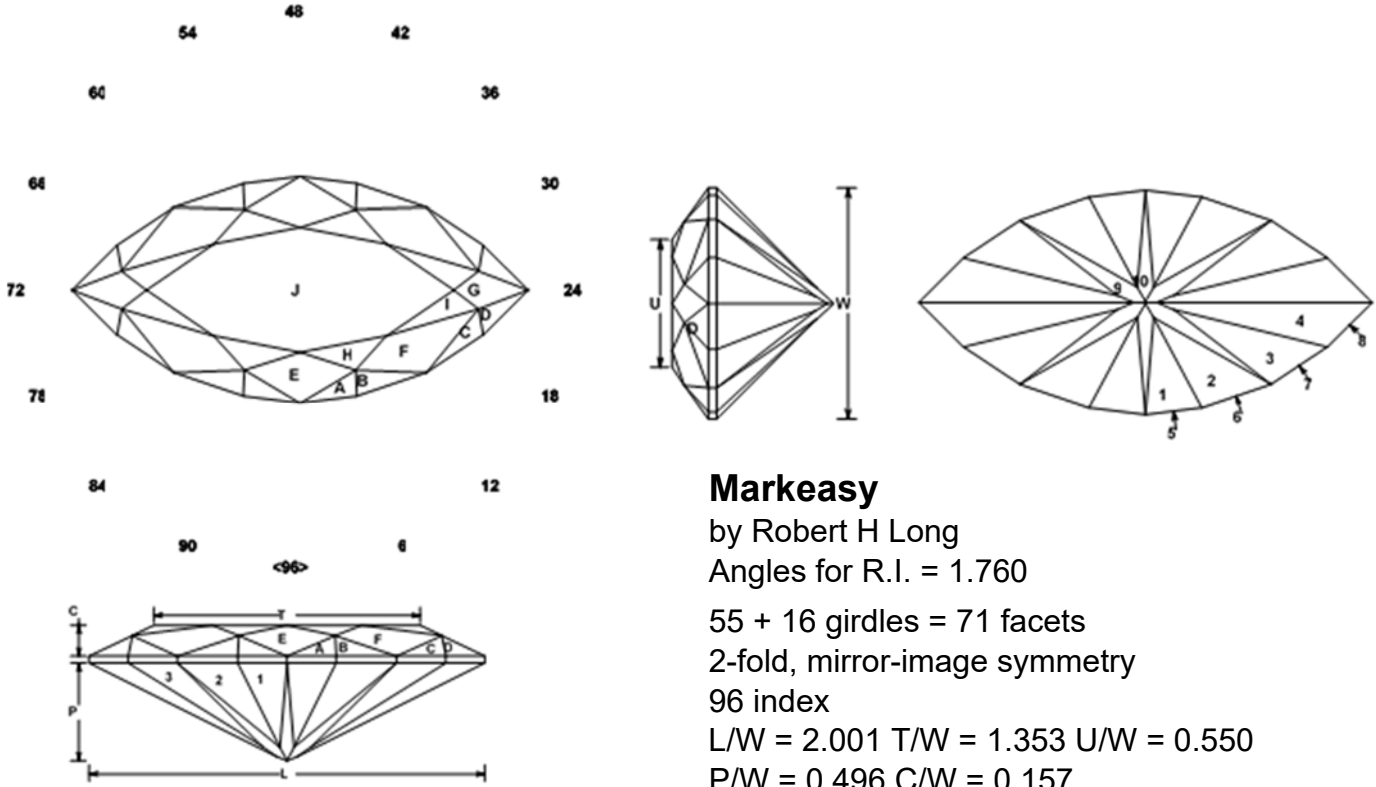

Markeasy

by Robert H Long

Angles for R.I. = 1.760

55 + 16 girdles = 71 facets

2-fold, mirror-image symmetry

96 index

L/W = 2.001 T/W = 1.353 U/W = 0.550

P/W = 0.496 C/W = 0.157

Vol. /W³ = 0.425

PAVILION

1	45.40°	02-46-50-94	Cut to TCP
2	43.90°	05-43-53-91	Meet at TCP
3	39.50°	09-39-57-87	Meet at TCP
4	35.40°	12-36-60-84	Meet at TCP
5	90.00°	02-46-50-94	Set width
6	90.00°	05-43-53-91	Level girdle
7	90.00°	09-39-57-87	Level girdle
8	90.00°	12-36-60-84	Level girdle
9	41.00°	07-41-55-89	Meet 2 - 3 at girdle, form PCP
10	44.83°	96-48	Meet 1 - 1 at girdle & PCP

CROWN

A	41.90°	02-46-50-94	Set girdle thickness
B	42.89°	05-43-53-91	Level girdle
C	44.71°	09-39-57-87	Level girdle
D	47.72°	12-36-60-84	level girdle
E	35.00°	96-48	Meet A - B - 5
F	35.00°	07-41-55-89	Meet A - B - C - 5 - 6
G	25.91°	24-72	Meet C - D - F - 7- 8
H	23.50°	03-45-51-93	Meet A - B - E - F
I	22.00°	09-39-57-87	Meet C - D - F - G - H
J	0.00°	Table	Meet E - H - F - I - G

2024 GEMKHANA

Section: I-10.2 The Gold Octagon

Material: Any Coloured MM Corundum

Facets: 53 + 8 girdles = 61 (Crown=29 Pavilion=32)

Meets: 21 (Crown =12 Pavilion=9)

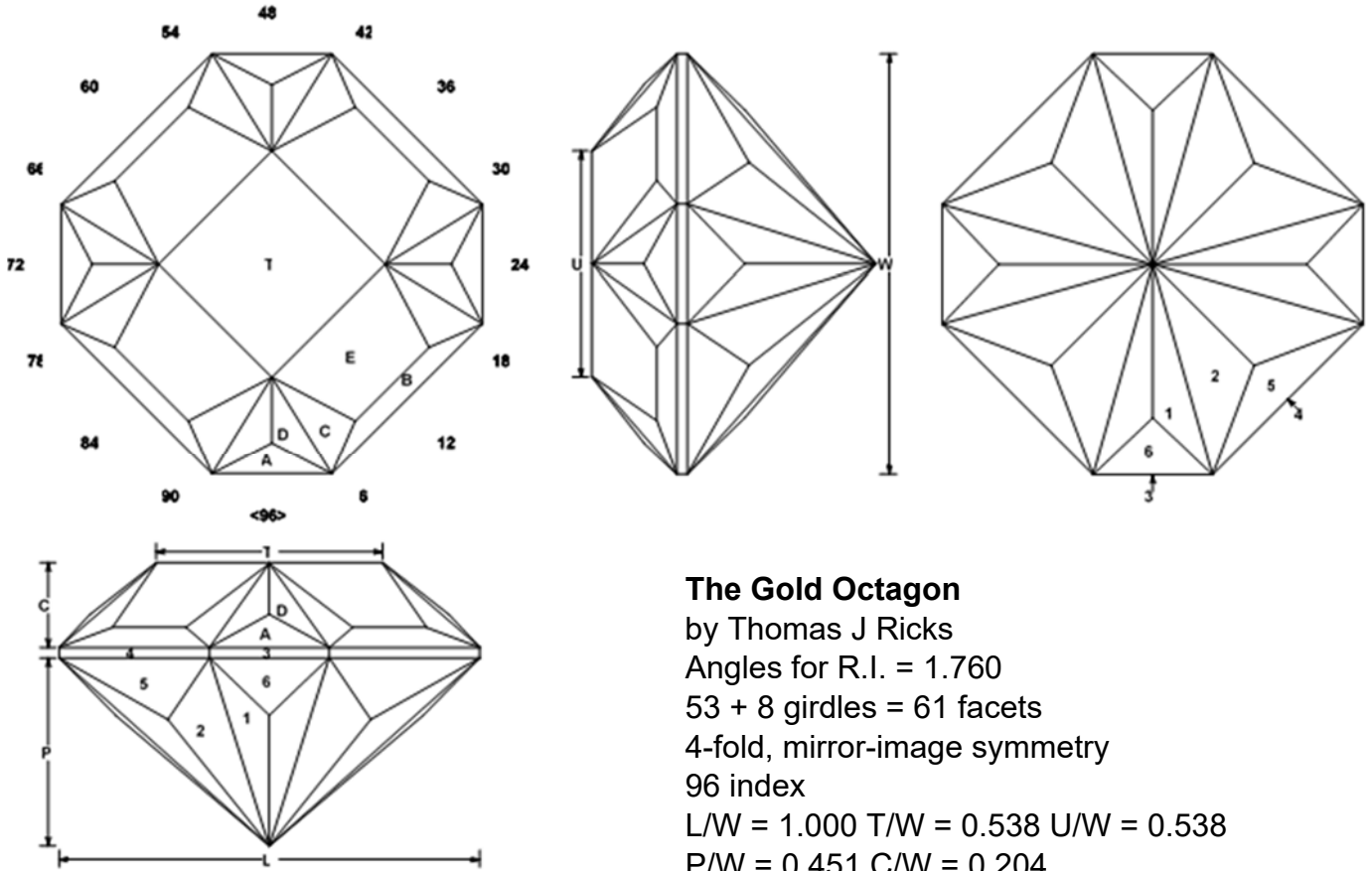

The Gold Octagon

by Thomas J Ricks

Angles for R.I. = 1.760

53 + 8 girdles = 61 facets

4-fold, mirror-image symmetry

96 index

L/W = 1.000 T/W = 0.538 U/W = 0.538

P/W = 0.451 C/W = 0.204

Vol. /W³ = 0.224

PAVILION

1	41.00°	03-21-27-45- 51-69-75-93
2	42.29°	09-15-33-39- 57-63-81-87
3	90.00°	96-24-48-72
4	90.00°	12-36-60-84
5	52.07°	12-36-60-84
6	45.99°	96-24-48-72

Cut to PCP

Meet PCP

Meet 1-2, set size

Meet 1-2-3, complete shaping

Meet 1-2-3-4, level girdle

Level girdle

CROWN

A	47.51°	96-24-48-72
B	45.00°	12-36-60-84
C	36.96°	10-14-34-38- 58-62-82-86
D	38.63°	03-21-27-45- 51-69-75-93
E	35.59°	12-36-60-84
T	0.00°	Table

Set girdle thickness

Level girdle

Meet A-B, 3-4

Meet A-B-C, 3-4

Meet C-D-D-C

Meet D-C-E

2024 GEMKHANA

Section: N-10.3 Australian Star

Material: Any Coloured MM Corundum

Facets: 55 + 6 girdles = 61 (Crown=25 Pavilion=30)

Meets: 31 (Crown =18 Pavilion=13)

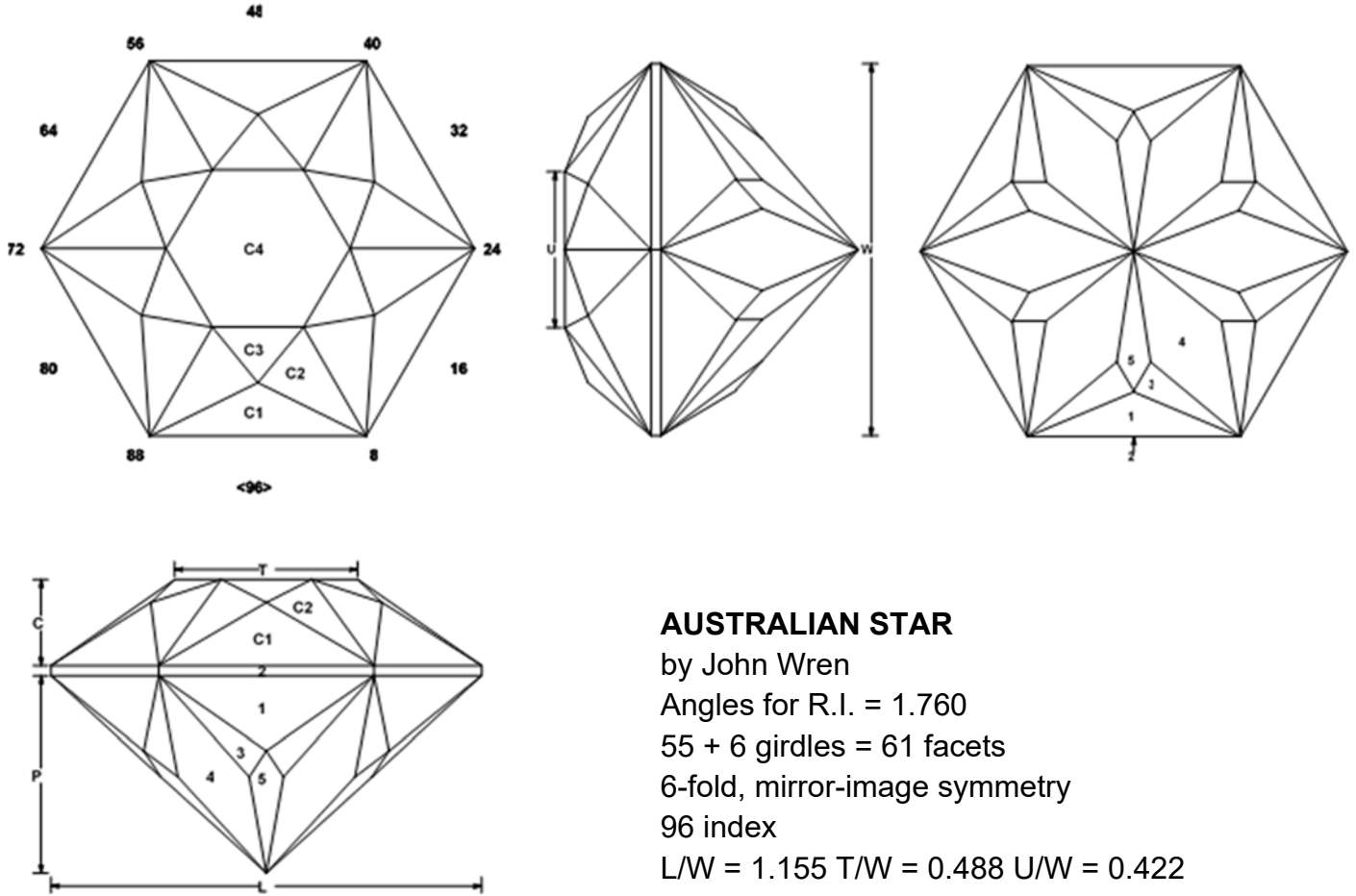

AUSTRALIAN STAR

by John Wren

Angles for R.I. = 1.760

55 + 6 girdles = 61 facets

6-fold, mirror-image symmetry

96 index

$L/W = 1.155$ $T/W = 0.488$ $U/W = 0.422$

$P/W = 0.533$ $C/W = 0.232$

$Vol. /W^3 = 0.321$

PAVILION

1	59.33°	96-16-32-48-64-80	Cut to TCP
2	90.00°	96-16-32-48-64-80	Set size
3	46.72°	04-12-20-28-36-44-52-60-68-76-84-92	Meet 1, 2, form new TCP
4	42.71°	08-24-40-56-72-88	Meet 1, 2, 3, form PCP
5	41.00°	96-16-32-48-64-80	Meet 1, 3, PCP

CROWN

C1	50.00°	96-16-32-48-64-80	Set girdle thickness
C2	35.00°	06-10-22-26-38-42-54-58-70-74-86-90	Meet C1, 2
C3	23.00°	96-16-32-48-64-80	Meet C1, C2
C4	0.00°	Table	Meet C2, C3

2024 GEMKHANA

Section: O-11.1 Sirius

Material: Any Coloured Cubic Zirconia

Facets: 54 + 12 girdles =66 (Crown=24 Pavilion=30)

Meets: 38 (Crown =19 Pavilion=19)

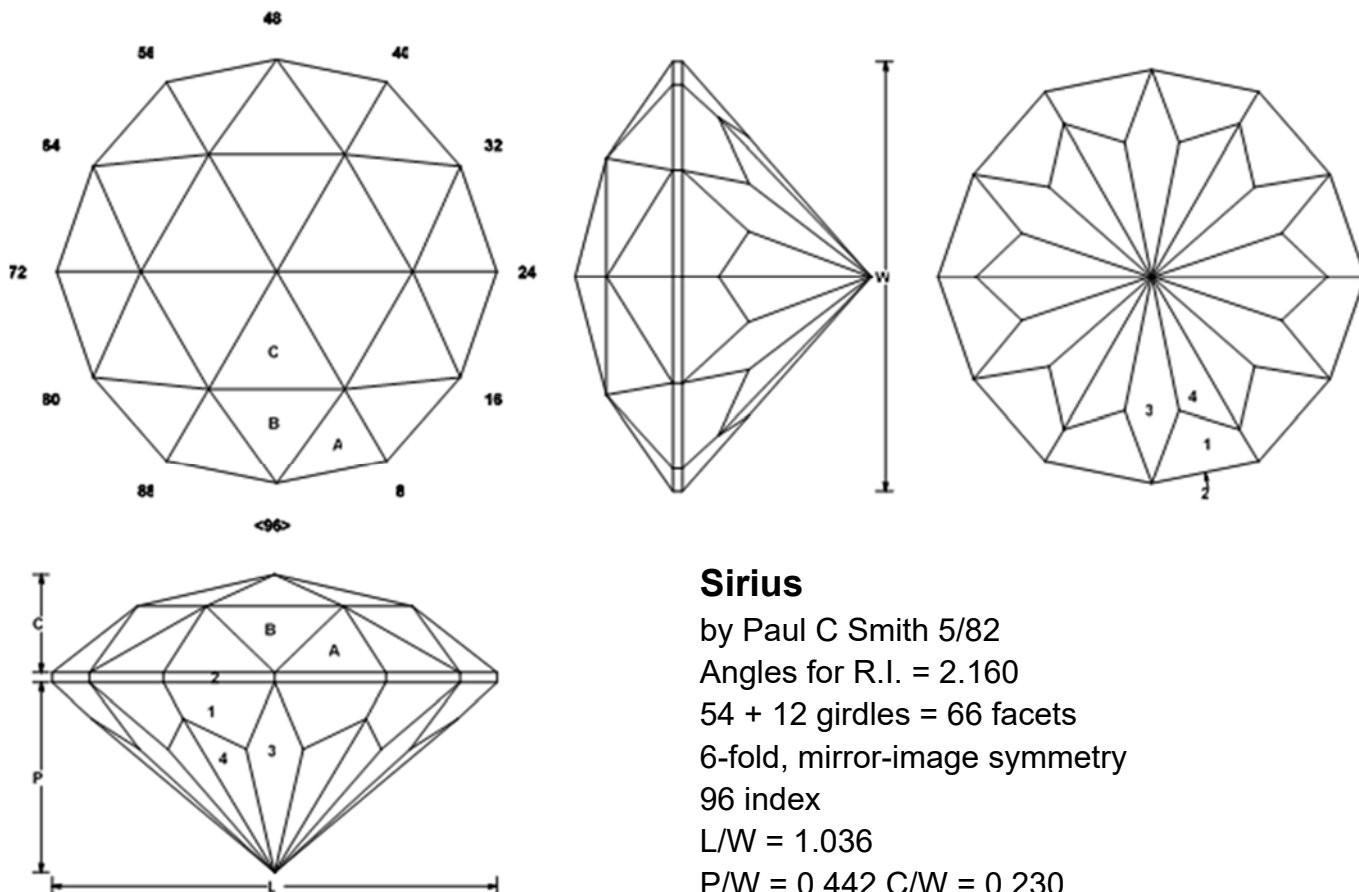

Sirius

by Paul C Smith 5/82

Angles for R.I. = 2.160

54 + 12 girdles = 66 facets

6-fold, mirror-image symmetry

96 index

L/W = 1.036

P/W = 0.442 C/W = 0.230

Vol. /W³ = 0.222

PAVILION

1	44.25°	03-13-19-29-35-45- 51-61-67-77-83-93	Form TCP
2	90.00°	03-13-19-29-35-45- 51-61-67-77-83-93	Set size
3	41.50°	96-16-32-48-64-80	Meet 1-2 form PCP
4	41.00°	04-12-20-28-36-44- 52-60-68-76-84-92	Meet PCP

CROWN

A	39.83°	03-13-19-29-35-45- 51-61-67-77-83-93	Set girdle thickness
B	35.00°	96-16-32-48-64-80	Meet A-2
C	15.00°	96-16-32-48-64-80	Meet A-B form Apex

2024 GEMKHANA

Section: I-11.2 Brilliant Fire

Material: Any Coloured Cubic Zirconia

Facets: 80 + 8 girdles = 88 (Crown=32 Pavilion=48)

Meets: 50 (Crown =25 Pavilion=25)

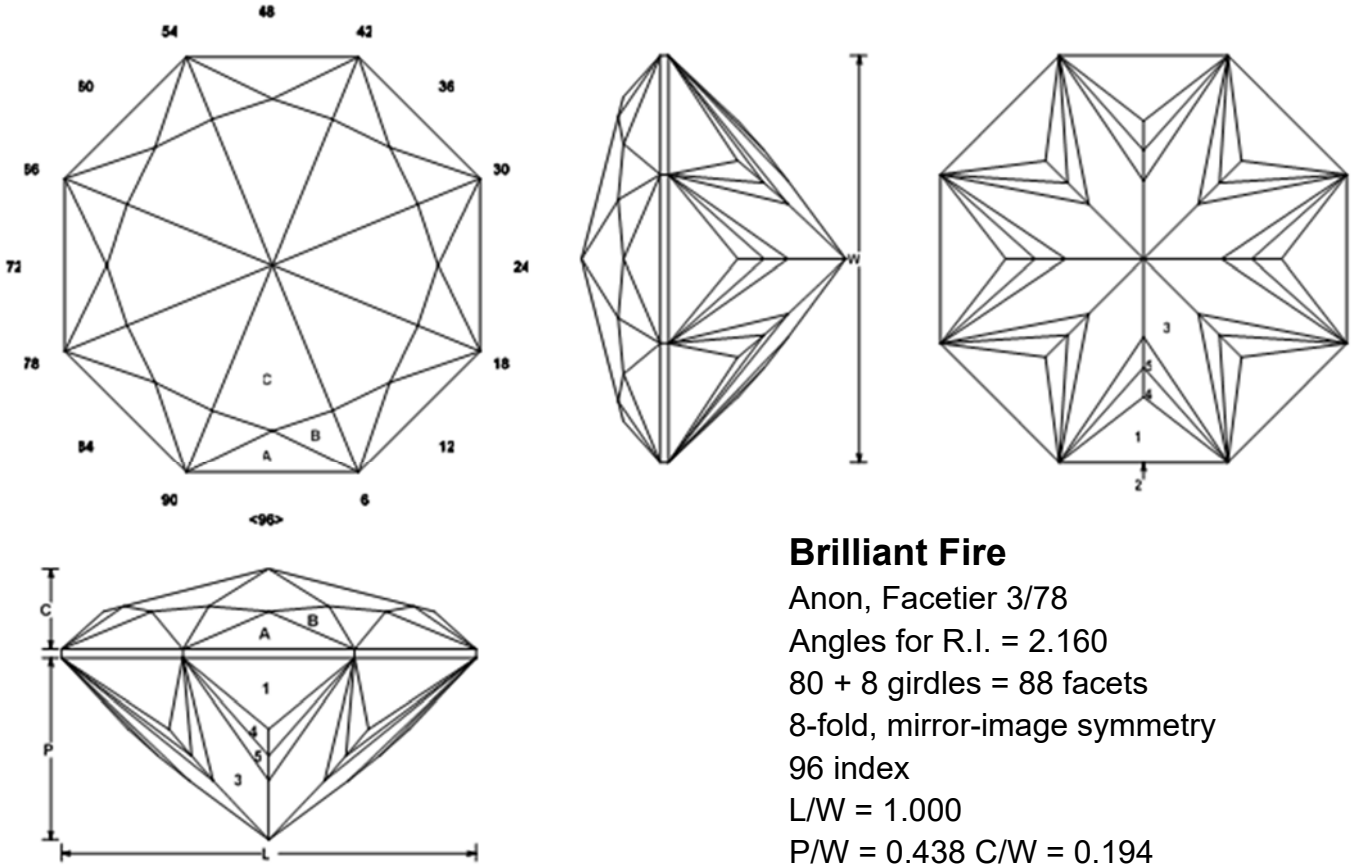

Brilliant Fire

Anon, Facetier 3/78
 Angles for R.I. = 2.160
 80 + 8 girdles = 88 facets
 8-fold, mirror-image symmetry
 96 index
 L/W = 1.000
 P/W = 0.438 C/W = 0.194
 Vol. /W³ = 0.225

PAVILION

1	46.97°	96-12-24-36-48-60-72-84	Form TCP
2	90.00°	96-12-24-36-48-60-72-84	Set size
3	39.00°	06-18-30-42-54-66-78-90	Meet 1-2 form PCP
4	41.00°	03-09-15-21-27-33-39-45- 51-57-63-69-75-81-87-93	Meet 1-2-3
5	40.00°	04-08-16-20-28-32-40-44- 52-56-64-68-76-80-88-92	Meet 1-2-3-4

CROWN

A	42.00°	96-12-24-36-48-60-72-84	Set girdle thickness
B	33.08°	03-09-15-21-27-33-39-45- 51-57-63-69-75-81-87-93	Meet A-2
C	14.51°	96-12-24-36-48-60-72-84	Meet A-B form Apex

2024 GEMKHANA

Section: N-11.3 Delta Apex Variation

Material: Any Coloured Cubic Zirconia

Facets: 33 + 9 girdles = 42 (Crown=118 Pavilion=15)

Meets: 25 (Crown =15 Pavilion=10)

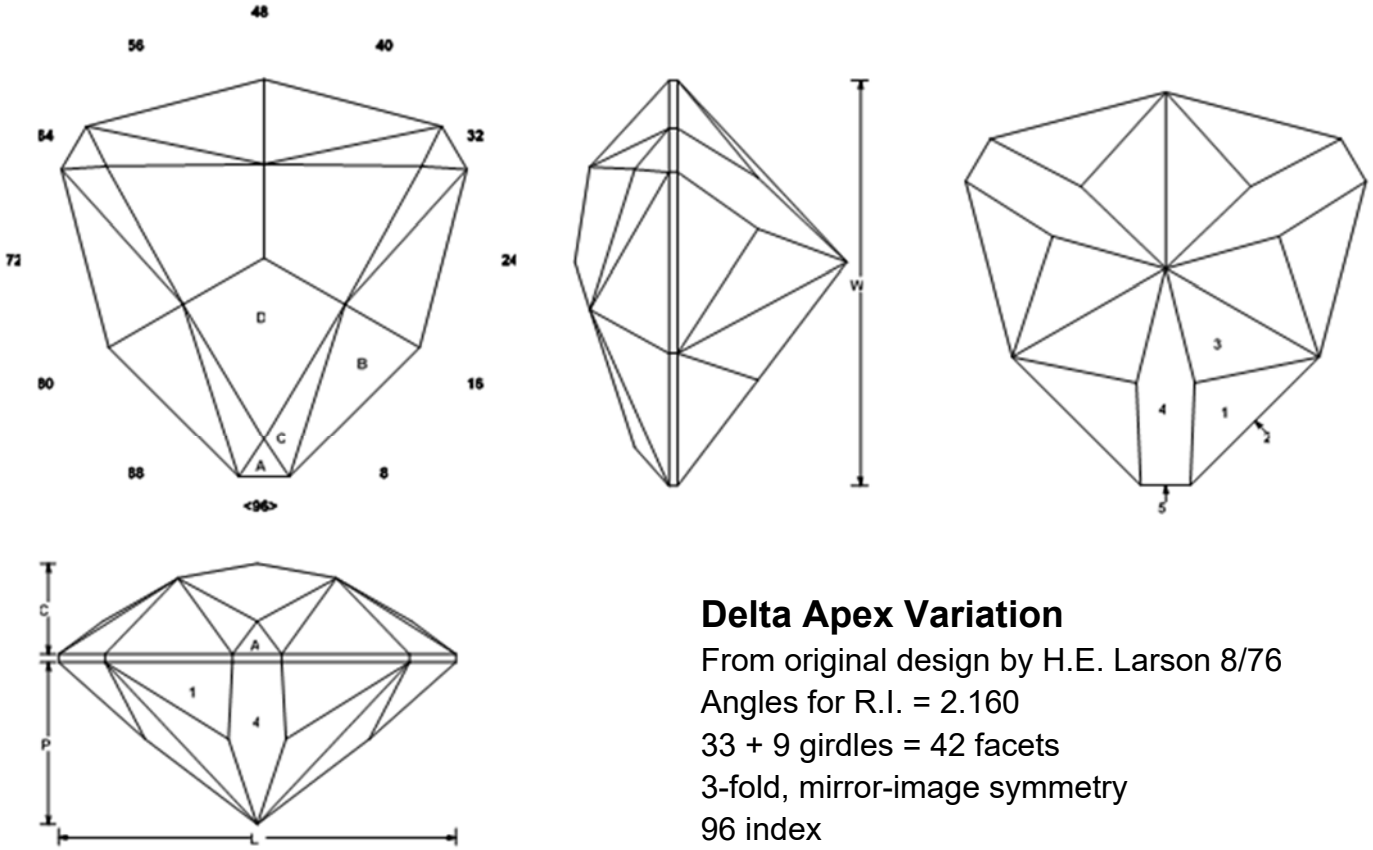

Delta Apex Variation

From original design by H.E. Larson 8/76

Angles for R.I. = 2.160

33 + 9 girdles = 42 facets

3-fold, mirror-image symmetry

96 index

L/W = 1.017

P/W = 0.415 C/W = 0.234

Vol. /W³ = 0.195

PAVILION

1	48.00°	12-20-44-52-76-84
2	90.00°	12-20-44-52-76-84
3	43.00°	14-18-46-50-78-82
4	37.00°	96-32-64
5	90.00°	96-32-64

- Form TCP
- Set size
- Meet 1-2 form PCP
- Meet PCP
- Cut corners, meet 1-2-4

CROWN

A	42.00°	96-32-64
B	43.19°	12-20-44-52-76-84
C	37.00°	10-22-42-54-74-86
D	18.00°	96-32-64

- Set girdle thickness
- Meet A-2, level girdle
- Meet A-B-2-5
- Meet A-C, B-C form Apex