



GEMKHANDA 2021

COMPETITION SCHEDULE AND CONDITIONS

GEMKHANA 2021 – COMPETITION SCHEDULE AND CONDITIONS

GENERAL CONDITIONS

1. This is a Level 3 Competition and will be judged in accordance with the rules and definitions of the ***Competitor & Judging Manual for Lapidary and Allied Competitions Issue no. 8 April 2015***. (referred to in this Schedule as the Manual), unless otherwise stated in this Schedule.
2. All competitors are advised to familiarise themselves with all the “Conditions for Competitors” in the Manual (particularly pages 5 to 13)
3. Competitors should be aware of, or check their eligibility to enter a Novice or Intermediate Division either by: -
 - ✓ Reading Section B4 of the manual (pages 6 & 7) relating to Competition Divisions, or by
 - ✓ checking the updated results list on the AFLACA website (<http://aflaca.org.au>)
4. Enquiries, correspondence, and ALL POSTAL ENTRIES relating to this Competition should be directed to:

GEMKHANA Competition Committee 2021
P.O. Box 109
Gymea NSW 2227
Phone enquiries to Colin Wright: 0418 286 003

5. Maximum number of entries allowed is two (2) per person per section except for Showcase Sections where only one entry per person is allowed.
6. It is the Competitor’s responsibility to ensure that their entries are entered in the correct section and that the sections are correctly marked on the Entry Form. If in doubt ring the Competition Committee.

However, the Competition Committee may transfer an entry into another section if they are of the opinion that it has obviously been enter in the incorrect section.

7. Entry Fees: - \$1.00 per entry for the first 10 entries, thereafter free.
(Payable by cheque or money order to Gem & Lapidary Council of NSW Inc)
8. All entries not being collected in person at the GEMKHANA must be accompanied by the **cost of return** post or **pre-paid post bag** included with the entry form (see Page 13).
9. While every care will be taken, the GEMKHANA 2021 Committee will not accept any responsibility for the loss or damage of any entries or exhibits that may occur in transit or whilst in the possession of the GEMKHANA 2021 committee.
10. Competitors and exhibitors are responsible for the insurance of their entries or exhibits while in transit, and whilst in the possession of the GEMKHANA 2021 Committee.

11. How to enter the Competition – Sections 1 to 4, 8 to 13 and 18 to 26

- a. Package up your entries to cushion them from damage whilst in transit – also see SC3.
- b. Fill out an official entry form – see page 13 of this Schedule.
- c. If you want acknowledgement of receipt of your entries, include a stamped, self-addressed envelope.
- d. Organise a cheque or money order payable to the Gem & Lapidary Council of NSW Inc for the entry fees (and return express postage if you are not collecting the entries in person at the Gemkhana.
- e. Submit your Entries + Entry Form + All fees to the Competition Committee.
This can either be: -

- ✓ By Express post to
GEMKHANA 2021 Committee
P.O. Box 109
GyMEA NSW 2227

They must be received by Friday 20th August 2021

- ✓ By hand delivery to
Port Hacking Lapidary Club
Rear 39 GyMEA Bay Rd.,
GyMEA

Between 8.00 am and noon on Saturday 21st August 2021

NOTE that late entries will not be eligible for competition and will be returned.

12. How to Enter the Competition – Sections 5, 16, 17, 29, 32, 34 and showcases

- a. Send your Entry Form and All Entry Fees to **arrive by Friday 20th August 2021** to:-
GEMKHANA 2021 Competition Committee
P.O. Box 109
GyMEA NSW 2227
- b. Hand deliver the entries to the Competition committee in the Competition Hall **at the GEMKHANA 2021 VENUE** between **1pm and 5pm on Friday 24th September 2021**
- c. Note that entries in Sections 29, 32 & 34 must be set up and ready in the Exhibition Hall by **5.00pm Friday 24th September 2021**

13. Judging, Judging Sheets and Entry Pickup

- a. Entries in Sections 1 to 4, 8 to 13, 18 to 26 will be judged prior to the GEMKHANA.
- b. Entries in Sections 5, 16, 17, 29, 32, and 34 will be judged at the GEMKHANA.
- c. Judging Sheets may be collected from the Competition Office between 10am and 12 noon on **Sunday 26th September 2021**
- d. Entries may be collected after **5.00pm Sunday 26th September 2021**
- e. Entries not collected will be returned to the competitor in the manner specified on the entry form together with the applicable judging sheets.

14 SPECIAL CONDITIONS (SC)

SC1 – Sizes and Tolerances

Where an entry does not conform to the size conditions in this Schedule or the Manual it will be ruled ineligible and not judged. Refer to section definitions in the Schedule and the Manual for allowable tolerances.

SC2 – Carving (Section 5)

Each entry must have a label which best describes the exhibit for the viewer's interest including the material used. These labels will not be judged.

SC3 - Facet Entries (Section 8 to 11)

- a. All chosen designs have either been previously used in competitions or have been successfully test cut using instructions given
- b. **ALL** Facets are **FLAT**, any entry with Concave or Curved facets (except Section 8A continuous girdle) will be disqualified and will NOT be judged.
- c. **Minimum size** is 6mm measured across shortest axis of outline shape at the girdle, or as " **indicated on design sheet**".
- d. Each faceted stone must be entered in a display box and this box must contain a label which contains only the following details:
 - Section Number
 - Material used
 - Colour of material
 - Size of stone

SC4 – Tumbled Stones (Section 12A)

Please read page 19 (D2.2) and page 55 (D12.1) of the Manual for definition of this section.

SC5 – Jewellery (Sections 18 – 26)

Competitors should carefully read Part E of the Manual in relation to all Jewellery Sections.

15 TROPHIES AND MEDALLIONS

1. Medallions and prize cards will be awarded for 1st, 2nd, and 3rd placed entries. Highly Commended will receive a prize card only.
2. At the Committee's discretion, where there are insufficient entries in a Novice or Intermediate Sections, a Special Award May be nominated and such an award will not exclude a competitor from entering the same section in future competitions.
3. To be eligible in winning a 'Dick Moppett Trophy: in faceting, entries must achieve a minimum of 70 points for Novice and 90 points for Open.

4. Annual Trophies may be awarded in the following categories: -

SPECIAL ONE-OFF TROPHIES

Donated by Gem & Lapidary Council of NSW

Section N-1A.3 Novice Standard Cabochon -C/S-Highest Score

Section O-13.1 Open Polished Face-Flat Surface-Highest Score

Section N-19A.2 Novice Cast Jewellery not intended to include Lapidary, Fossil, or Mineral Item/s-Highest Score

THE JOAN BALL TROPHIES

Section O-26B.1 Open Enamelled Jewellery without Mount -Highest Score

Section O-17.1 Open Novelty Gem Craft-Highest Score

THE ALAN COULTON TROPHY

Section O-20A.1 Open Cast Jewellery using Natural Objects as Patterns -Highest Score

5. Perpetual Trophies may be awarded for the following:-

THE BORIS NOVIC TROPHY

Section O-2A.1 The competitor with the highest score in Section O-2A.1 Double Standard Cabochon – C/S

THE DICK MOPPETT TROPHY – NOVICE

Sections N-8B.3 & N-9B.3 For the Novice competitor with the highest aggregate point for two (2) faceted stones - one shall be **STANDARD BRILLIANT** and the other a **STANDARD STEP CUT**. Note that each entry must achieve a minimum standard of **70 points**.

THE DICK MOPPETT TROPHY – OPEN

Sections O-8B.1 & O-9B.1 For the Open Competitor with the highest aggregate points for two (2) faceted stones – one shall be **STANDARD BRILLIANT** and the other a **STANDARD STEP CUT**. Note that each entry must achieve a minimum standard of **90 points**.

THE ARTHUR ROFFEY TROPHY for “BEST MINERAL IN SHOW”

(As selected by the donor)

THE FRANK LANDER TROPHY for MOST SUCCESSFUL COMPETITOR

Points are awarded as: - 1st place – 6 points 2nd place – 4 points 3rd place – 2 points .
Highly Commended = 1 point. Special Award – 6 points

THE FRANK HALL TROPHY for MOST SUCCESSFUL CLUB

Points awarded as: - 1st place – 6 points, 2nd place – 4 points, 3rd place – 2 points.
Highly commended – 1-point, Special award – 6 points. Entries within 75% of the winning entry's score – 1 point.

GEMKHANA 2021 – COMPEITION SCHEDULE AND CONDITIONS

Judging will be in accordance with the AFLACA Competition and Judging Manual Issue No. 8

O= Open I = Intermediate N = Novice J = Junior TR = Trophy

C/S = Craftsmanship A/A = Aesthetic Appeal SC = Special Condition Applies

Standard Cabochon – Must not pass through a 15mm hole (SCI)

O-1A.1	Standard Cabochon	C/S – Any Material	
I-1A.2	Standard Cabochon	C/S – Any Material	
N-1A.3	Standard Cabochon	C/S – Any Material	TR
J-1A.4	Standard Cabochon	C/S - Any Material	
O-1A.5	Standard Cabochon	A/A Any Obsidian	
I-1A.6	Standard Cabochon	A/A Any Obsidian	
N-1A.7	Standard Cabochon	A/A Any Obsidian	
J-1A.8	Standard Cabochon	A/A Any Obsidian	

Fancy Cabochon – Must not pass through a 15mm hole (SCI)

O-1B.1	Fancy Cabochon	C/S – Mookaite	
I-1B.2	Fancy Cabochon	C/S – Mookaite	
N-1B.3	Fancy Cabochon	C/S – Mookaite	
J-1B.4	Fancy Cabochon	C/S – Mookaite	
O-1B.5	Fancy Cabochon	A/A – Any Material	
I-1B.6	Fancy Cabochon	A/A – Any Material	
N-1B.7	Fancy Cabochon	A/A – Any Material	
J-1B.8	Fancy Cabochon	A/A – Any Material	

Double Standard Cabochon - must not pass through a 15mm hole (SCI)

O-2A.1	Double Standard Cabochon	C/S – Any material	TR
I-2A.2	Double Standard Cabochon	C/S – Any material	
N-2A.3	Double Standard Cabochon	C/S – Any material	

Double Fancy Cabochon – Must not pass through a 15 mm hole (SCI)

O-2B.1	Double Fancy Cabochon	C/S – Any Material	
I-2B.2	Double Fancy Cabochon	C/S – Any Material	
N-2B.3	Double Fancy Cabochon	C/S – Any Material	

Freeform – Must not pass through 15mm hole (SCI)

O-3.1	Freeform	C/S – Ribbon Stone
I-3.2	Freeform	C/S – Ribbon Stone
N-3.3	Freeform	C/S – Ribbon Stone
J-3.4	Freeform	C/S – Ribbon Stone

Opal Freeform – Must not pass through 10mm hole (SCI)

O-3.5	Freeform	C/S – Opal Solid
N-3.6	Freeform	C/S – Opal Solid

Opal Doublets- Must not pass through 10mm hole (SCI)

O-4A	Opal Doublet – Flat Top
O-4B	Opal Doublet – Domed Top

Carving – Hardness under 4 – Minimum size 50mm on the longest dimension (excluding base or mount) – Maximum size 300mm (including base of mount) (SCI and SC2)

O-5A.1	Carving – 3 dimensional
N-5A.2	Carving – 3 dimensional

Carving – Any Hardness – Minimum size 50mm on the longest dimension (excluding base or mount) Maximum size 300mm (including base or mount) (SC1 and SC2)

O-5B.1	Carving – in relief
N-5B.2	Carving – in relief

Carving – any hardness – minimum size 50 mm on the longest dimension (excluding base or mount) – maximum size 300mm (including base or mount) (SCI and SC2)

O-5E.1	Carving not otherwise specified in Groups 5A to 5D
N-5E.2	Carving not otherwise specified in Groups 5A to 5D

Facet Cuts – Minimum size 6mm on shortest axis of outline shape (or as indicated on design sheet)– Groups 8, 9, 10 and 11 – (SC1 and SC3)

O-8A.1, I-8A.2, N-8A.3	Standard Round Brilliant with faceted girdle	Any CLEAR Quartz	TR
O-9B.1, I-9B.2, N-9B.3	Square Step Cut with Cut corners	MM Coloured Spinel	TR
O-10.1	Modified Standard Cut – TRIXIE	MM Coloured Corundum	
O-10.2	Modified Standard Cut – MIRRETTA’s CUSHION	MM Coloured Corundum	
I-10.3	Modified Standard Cut – EASY CUSHION	Any Topaz	
I-10.4	Modified Standard Cut – MIXED CUT	MM Coloured Cubic Zirconia	
N-10.5	Modified Standard Cut – DOUBLE TRIPLE	Any Clear Quartz	
N-10.6	Modified Standard Cut – USFG-1	MM Coloured Spinel	
J-10.7	Modified Standard Cut – JUNIOR ASHER CUT	Any Clear Quartz	
O-11.1	Fancy Cut – ROBIN	MM Coloured Cubic Zirconia	
I-11.2	Fancy Cut – MINI HEXAGON APEX	MM Coloured Spinel	
N-11.3	Fancy Cut - OLD MINE BARION	MM Coloured Cubic Zirconia	

Tumbled Stones – must not be able to pass through a 15mm diameter hole (SC4)

O-12A.1	Tumbled Stones – Preformed Shape	Group of 3 different materials
N-12A.2	Tumbled Stones – Preformed Shape	Group of 3 – Any material

Polished Face – Minimum size 50mm across shortest axis – Maximum size 300mm on any dimension

O-13.1	Polished Flat Surface	C/S	TR
N-13.2	Polished Flat Surface	C/S	
J-13.3	Polished Flat Surface	C/S	
O-14.1	Polished Curved Surface	A/A	
N-14.2	Polished Curved Surface	A/A	
J-14.3	Polished Curved Surface	A/A	

Gem Trees -Min must not fit into a 150 mm cube, Max must fit into a 300 mm cube (SC1)

O-16.1	Gem Tree
N-16.2	Gem Tree

Novelty Gemcraft – Minimum size 50mm on the longest dimension excluding base (SC1)

O-17.1	Novelty Gem craft	TR
N-17.2	Novelty Gem craft	

Hand Fabricated and Wire Wrapped Jewellery (SC5)

O-18A.1	Hand Fabricated Jewellery Specimen (s)	NOT intended to include Lapidary, Fossil or Mineral
I-18A.2	Hand Fabricated Jeweller – Specimen (s)	NOT intended to include Lapidary, Fossil or Mineral
N-18A.3	Hand Fabricated Jewellery – Specimen (s)	NOT intended to include Lapidary, Fossil or Mineral
O-18B.1	Hand Fabricated Jewellery--	WITH lapidary Item (s) cut and set by entrant
I-18B.2	Hand Fabricated Jewellery –	WITH lapidary item(s) cut and set by entrant
N-18B.3	Hand Fabricated Jewellery –	WITH lapidary item(s) cut and set by entrant
O-18E.1	Wire Wrapped Jewellery-	WITH Lapidary, Fossil or Mineral Items(s) prepared/ set by entrant
N-18E.2	Wire Wrapped Jewellery	WITH Lapidary. Fossil or Mineral Item (s) prepared/ Set by entrant

Cast Jewellery – using Patterns, mould or Dies MADE BY ENTRANT (SC5)

O-19A.1	Cast Jewellery	NOT intended to include Lapidary Fossil or Mineral Item(s)
N-19A.2	Cast Jeweller	NOT intended to include Lapidary Fossil or Mineral Item(s) TR

Metal Clay Jewellery – using Patterns, Moulds or Dies MADE BY ENTRANT (SC5)

O-19E.1	Metal Clay Jewellery	NOT intended to include Lapidary, Fossil or Mineral Item(s)
N-19E.2	Metal Clay Jewellery	NOT intended to include Lapidary Fossil or Mineral Item(s)

Cast Jewellery – using Natural Objects as Patterns (SC5)

O-20A.1	Cast Jewellery	NOT intended to include Lapidary Fossil or Mineral Item(s) TR
N-20A.2	Cast Jewellery	NOT intended to include Lapidary Fossil or Mineral Item(s)

Metal Clay Jewellery – using natural Object as Patterns (SC5)

- O-20E.1 Metal Clay Jewellery **NOT** intended to include lapidary, fossils or minerals
N-20E.2 Metal Clay Jewellery **NOT** intended to include lapidary, fossils or minerals

Cast Jewellery – using Commercial Wax Models or Patterns (SC5)

- O-21B.1 Cast Jewellery **WITH** Lapidary Item(s) Cut and Set by Entrant
N-21B.2 Cast Jewellery **WITH** Lapidary Item(s) Cut and Set by Entrant

Metal Clay Jewellery – using Commercial Wax Models or Patterns (SC5)

- O-21G.1 Metal Clay Jewellery **WITH** Commercial Lapidary Item(s) set by Entrant
N-21G.2 Metal Clay Jewellery **WITH** Commercial Lapidary Item(s) set by Entrant

Combined Jewellery – with Lapidary Items cut and set by Entrant (SC5)

- O-23B.1 Combined Jewellery **WITH** lapidary items cut & set by Entrant

Enamelled Jewellery in Hand Fabricated Setting (SC5)

- O-24A.1 Enamelled Jewellery in hand fabricated setting
N-24A.2 Enamelled Jewellery in hand fabricated setting

Commercial Mount Jewellery (SC5)

- O-25.1 Commercial Mount Jewellery **WITH** Lapidary item(s) cut and set by entrant
I-25.2 Commercial Mount Jewellery **WITH** Lapidary item(s) cut and set by entrant
N-25.3 Commercial Mount Jewellery **WITH** Lapidary item(s) cut and set by entrant

Enamelling Sections (SC5)

- O-26A.1 Enamelled Jewellery in Commercial Mount
N-26A.2 Enamelled Jewellery in Commercial Mount
O-26B.1 Enamelled Jewellery without Mount **TR**
N-26B.2 Enamelled Jewellery without Mount
O-26C.1 Enamelling – non-Jewellery
N-26C.2 Enamelling – non-Jewellery

Showcases

O-29B.1 Showcase General – LIT

Fossils

O-32A.1 Fossils Non-Display Any Locality

N-32A.2 – Fossils Any locality
Non-Display

O-32B.1 Fossils Non-Display Group of 3 Invertebrates

N-32B.2 Fossils Non-Display Group of 3 Invertebrates

Minerals

O-34A.1 Mineral Non-Display Single Specimen Any Locality Cabinet Size

N-34A.2 Mineral Non-Display Single Specimen Any Locality Cabinet Size

O-34A-3 Mineral Non-Display Single Specimen Any Locality Miniature

N-34A.4 Mineral Non-Display Single Specimen Any Locality Miniature

O-34B.1 Mineral Non -Display Group of Three Any Locality Thumbnail

N-34B.2 Mineral Non -Display Group of Three Any Locality Thumbnail

GEMKHANA 2021 OFFICIAL ENTRY FORM

Mail to : The Competition Committee

PO Box 109, Gymea NSW 2227

Postal entries: All Entry Forms and fees must be RECEIVED BY THE COMMITTEE BY FRIDAY 20th August 2021

COMPETITOR DETAILS

Name:.....

Email:.....

Address:.....

State:.....Postcode:.....Personal Contact No:.....

Full Club Details:.....

For Juniors only, Date of birth...../...../..... (NB: Must be under 16 at 20th August 2021)

ENTRY SUMMARY AND FEES (Cheques made payable to Gem and Lapidary Council of NSW Inc)

No of Entries.....Are entries to be returned by mail ? (circle) Yes/No

Entry Fees: \$1.00 per entry for first 10 entries, thereafter free.....Amount \$.....

\$.....

Total Amount Enclosed \$.....

Signature of Competitor that entries are your own works.....

ENTRIES BY SECTIONS-postal (received by August 20th 2021) or drop off Sat 21st August 2021											
Section No.	Entries (1or2)	Section No.	Entries (1or2)	Section No.	Entries (1or2)	Section No.	Entries (1or2)	Section No.	Entries (1or2)	Section No.	Entries (1or2)
O-1A.1		I-1A.2		N-1A.3		J-iA.4		O-1A.5		I-1A.6	
N-1A.7		J-1A.8		O-1B.1		I-1B.2		N-1B.3		J-1B.4	
O-1B.5		I-1B.6		N-1B.7		J-1B.8		O-2A.1		I-2A.2	
N-2A.3		O-2B.1		I-2B.2		N-2B.3		O-3.1		I-3.2	
N-3.3		J-3.4		O-3.5		N-3.6		O-4A.1		O-4B.1	
O-8B.1		I-8B.2		N-8B.3		O-9B.1		I-9B.2		N-9B.3	
O-10.1		O-10.2		I-10.3		I-10.4		N-10.5		N-10.6	
J-10.7		O-11.1		I-11.4		N-11.3		O-12A.1		N-12A.2	
O-12B.3		N-12B.4		O-13.1		N-13.2		J-13.3		O-14.1	
N-14.2		J-14.3		O-18A.1		I-18A.2		N-18A.3		O-18B.1	
I-18B.2		N-18B.3		O-18E.1		N-18E.2		O-19A.1		N-19A.2	
O-19E.1		N-19E.2		O-20A.1		N-20A.2		O-20E.1		N-20E.2	
O-21B.1		N-21B.2		O-21G.1		N-21G.2		O-23B.1		O-24A.1	
N-24A.2		O-25.1		I-25.2		N-25.3		O-26A.1		N-26A.2	
O-26B.1		N-26B.2		O-26C.1		N-26C.2					

ENTRIES BY SECTION-Delivered & Setup by Entrant at GEMKHANA VENUE on Friday 24th Sept 2021											
Section No.	Entries (1or2)	Section No.	Entries (1or2)	Section No.	Entries (1or2)	Section No.	Entries (1or2)	Section No.	Entries (1or2)	Section No.	Entries (1or2)
O-5A.1		N-5A.2		O-5B.1		N-5B.2		O-5E.1		N-5E.2	
O-16.1		N-16.2		O-17.1		N-17.2		O-29B.1		O-32A.1	
N-32A.2		O-32B.1		N-32B.2		O-34A.1		N-34A.2		O-34A.3	
N-34A.4		O-34B.1		N-34B.2							

GEMKHANA 2021

Faceting Section:- O-8B-1 I-8B-2 N-8B-3

Material:- Any Clear Quartz

Facets:- 57 + 16 girdle=73 (crown 33 Pavilion 24)

Meets:- 57 (crown 32 Pavilion 25)

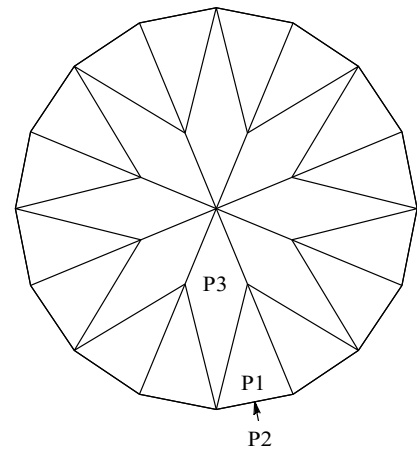
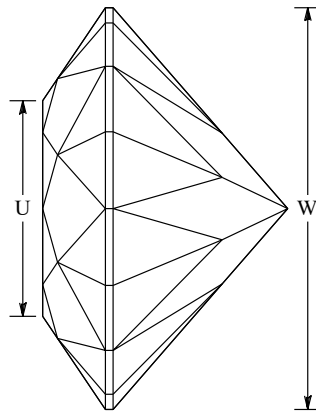
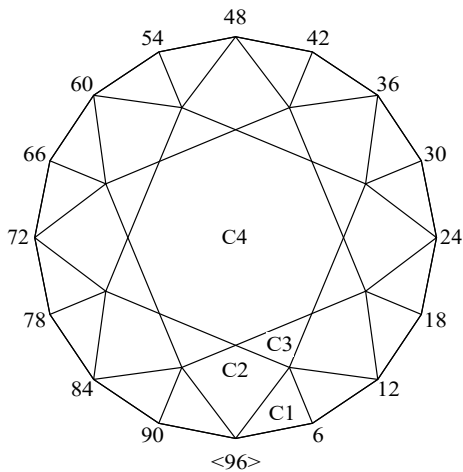

STANDARD ROUND BRILLIANT -Faceted Girdle

Angles for R.I. = 1.540

8-fold, mirror-image symmetry

96 index

$L/W = 1.000$ $T/W = 0.536$ $U/W = 0.536$

$P/W = 0.435$ $C/W = 0.156$

$Vol./W^3 = 0.205$

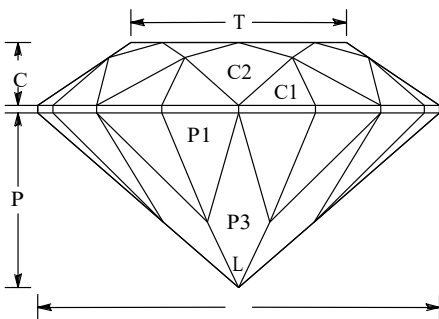

PAVILION

P1	43.00°	03-09-15-21-27-33-39-45-51-57-63-69-75-81-87-93	Cut to form TCP
P2	90.00°	03-09-15-21-27-33-39-45-51-57-63-69-75-81-87-93	Set stone size
P3	41.00°	96-12-24-36-48-60-72-84	Meet P1 at girdle a form PCP

CROWN

C1	39.00°	03-09-15-21-27-33-39-45-51-57-63-69-75-81-87-93	Set girdle thickness
C2	34.00°	96-12-24-36-48-60-72-84	Meet C1 at girdle
C3	20.00°	06-18-30-42-54-66-78-90	Meet C1-C2
C4	0.00°	Table	Meet C2-C3

GEMKHANA 2021

Section: O-10.1

Material: MM Coloured Corundum

Facets 55 + 15 Girdle = 70 (Crown 34 Pavilion 21)

Meets: 49 (Crown 27 Pavilion 22)

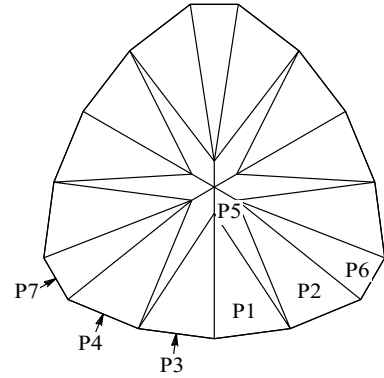
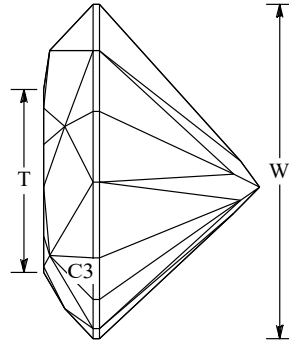
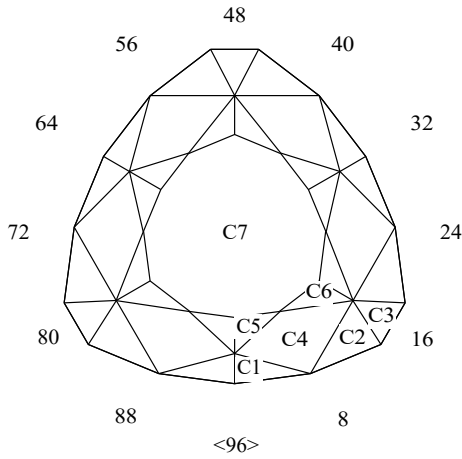

TRIXIE

Angles for R.I. = 1.760

55 + 15 girdles = 70 facets

3-fold, mirror-image symmetry

96 index

$L/W = 1.019$ $T/W = 0.547$ $U/W = 0.545$

$P/W = 0.479$ $C/W = 0.148$

$Vol./W^3 = 0.210$

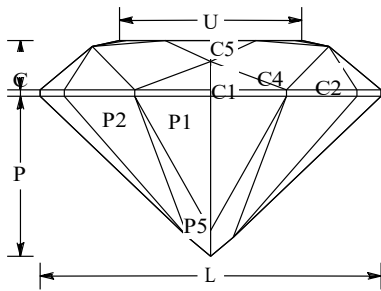

PAVILION

P1	47.21°	02-30-34-62-66-94	Form TCP
P2	45.44°	06-26-38-58-70-90	Meet TCP
P3	90.00°	02-30-34-62-66-94	Size Stone
P4	90.00°	06-26-38-58-70-90	Level girdle
P5	45.69°	04-28-36-60-68-92	Meet Girdle & form PCP
P6	42.00°	16-48-80	Meet P2- P5
P7	90.00°	16-48-80	Level girdle

CROWN

C1	43.59°	02-30-34-62-66-94	Set Girdle thickness
C2	40.18°	06-26-38-58-70-90	Level girdle
C3	43.13°	16-48-80	Level girdle
C4	36.00°	04-28-36-60-68-92	Meet C1 - C2
C5	30.39°	02-30-34-62-66-94	Meet C1-C4
C6	9.54°	10-22-42-54-74-86	Meet C2-C3-C4
C7	0.00°	Table	

GEMKHANA 2021

Section: O-10.2

Material: MM Coloured Corundum

Facets: 77 + 16 Girdle (Crown 37 Pavilion 40)

Meets: 72 (Crown 31 Pavilion 41)

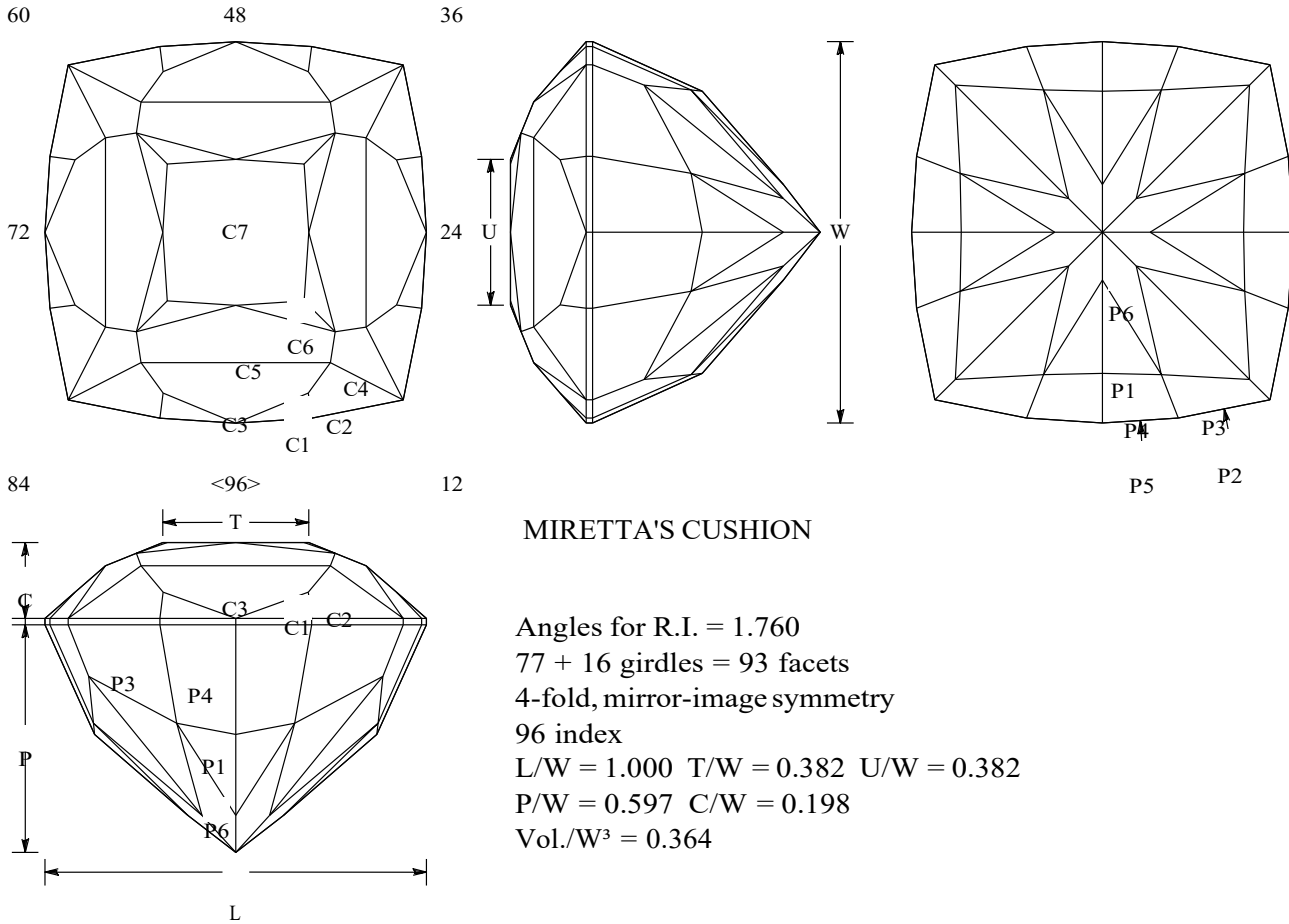

PAVILION

P1	41.50°	03-09-15-21-27-33-39-45-51-57-63-69-75-81-87-93	FORM TCP
P2	90.00°	03-21-27-45-51-69-75-93	Size Stone
P3	65.00°	03-21-27-45-51-69-75-93	MEET P1-P2
P4	65.70°	01-23-25-47-49-71-73-95	MEET P2-P3
P5	90.00°	01-23-25-47-49-71-73-95	Level girdle
P6	40.00°	06-18-30-42-54-66-78-90	Meet P1-P3-P4

CROWN

C1	46.00°	01-23-25-47-49-71-73-95	Set girdle thickness
C2	46.00°	03-21-27-45-51-69-75-93	Level girdle
C3	41.00°	96-24-48-72	Meet C1 at girdle
C4	34.00°	12-36-60-84	Meet C2 at corner
C5	22.00°	96-24-48-72	Meet C2-C4
C6	18.00°	01-23-25-47-49-71-73-95	Meet C4 -C5
C7	0.00°	Table	Meet C5-C6

2021 GEMKHANA

Section: I-10.3

Material: Any Topaz

Facets: 72 + 20 Girdle = 92 (Crown = 42 Pavilion = 30)

Meets: 73 (Crown = 42 Pavilion = 31)

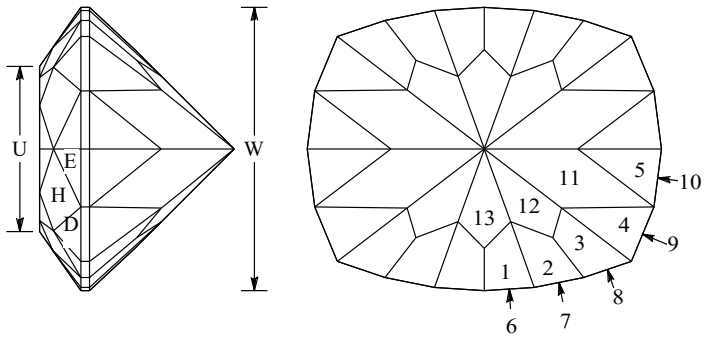
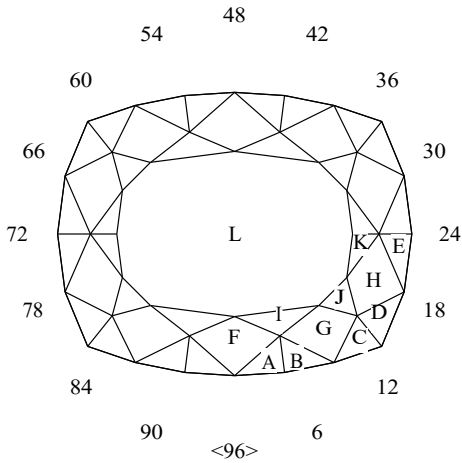

EASY CUSHION#2

Author Robert Long

Angles for R.I. = 1.610

73 + 20 girdles = 93 facets

2-fold, mirror-image symmetry

96 index

$L/W = 1.250$ $T/W = 0.832$ $U/W = 0.583$

$P/W = 0.511$ $C/W = 0.146$

$Vol./W^3 = 0.327$

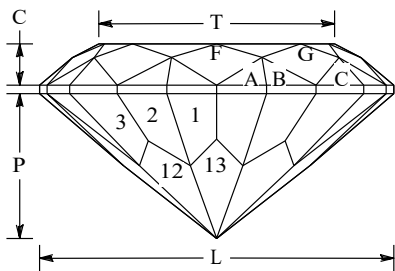

PAVILION

1	47.00°	01-47-49-95	Form TCP
2	46.18°	03-45-51-93	Meet TCP
3	44.61°	05-43-53-91	Meet TCP
4	40.30°	18-30-66-78	Meet TCP
5	40.81°	22-26-70-74	Meet TCP
6	90.00°	01-47-49-95	Set girdle line
7	90.00°	03-45-51-93	Level girdle
8	90.00°	05-43-53-91	Level girdle
9	90.00°	18-30-66-78	Level girdle
10	90.00°	22-26-70-74	Level girdle
11	45.03°	96-48	Set PCP
12	43.37°	04-44-52-92	Meet P1-P2 and PCP
13	39.00°	20-27-68-75	Meet @ girdle & PCP

CROWN

A	37.16°	01-47-49-95	Set girdle thickness
B	37.17°	03-45-51-93	Level girdle
C	36.67°	05-43-53-91	Level girdle
D	38.66°	18-30-66-78	Level girdle
E	40.24°	22-26-70-74	Level girdle
F	35.00°	96-48	Meet girdle
G	35.00°	04-44-52-92	Meet girdle
H	34.99°	20-28-68-76	Meet girdle
I	28.33°	02-46-50-94	Meet A-B-F-G
J	22.01°	12-36-60-84	Meet C-D-G-H
K	27.87°	22-26-70-74	Meet E-E-H-H
L	0.00°	Table	

GEMKHANA 2021

Section:- I-10.4

Material:- MM Coloured Cubic Zirconia

Facets:- 69 + 12 girdle = 81 (crown 29 Pavilion 52)

Meets:- 57 (Crown 24 Pavilion 33)

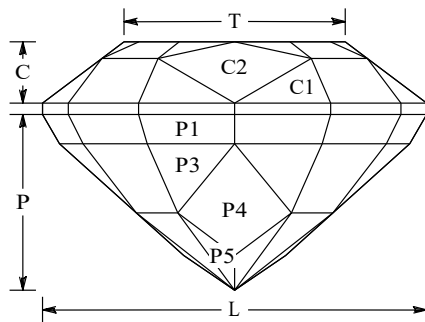
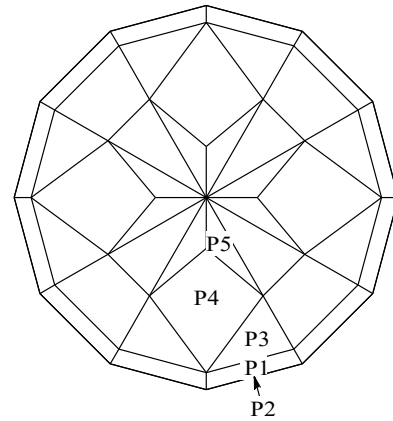
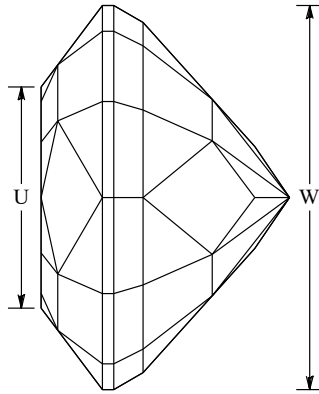
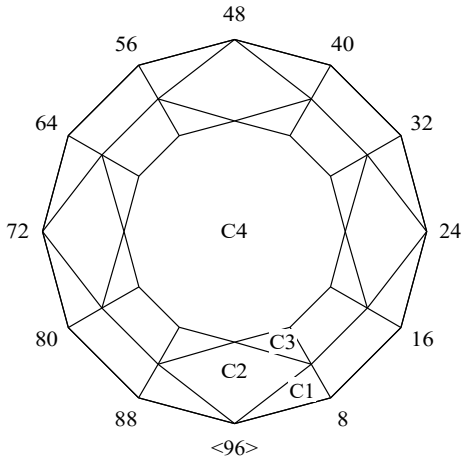

MIXED CUT

Author George Beard

Angles for R.I. = 2.160

69 + 12 girdles = 81 facets

$L/W = 1.000$ $T/W = 0.576$ $U/W = 0.576$

$P/W = 0.457$ $C/W = 0.160$

$Vol./W^3 = 0.251$

PAVILION

P1	60.70°	04-12-20-28-36-44- 52-60-68-76-84-92	Cut to TCP
P2	90.00°	04-12-20-28-36-44- 52-60-68-76-84-92	Size Stone
P3	49.30°	04-12-20-28-36-44- 52-60-68-76-84-92	Provide small step facet @ P1
P4	42.00°	96-24-48-72	Meet P1-P2
P5	35.20°	04-12-20-28-36-44- 52-60-68-76-84-92	Meet P2-P3 and form PCP

CROWN

C1	50.00°	04-12-20-28-36-44- 52-60-68-76-84-92	Set girdle thickness
C2	37.00°	96-24-48-72	Meet C1 @ girdle
C3	22.00°	04-12-20-28-36-44- 52-60-68-76-84-92	Meet C1- C2
C4	0.00°	Table	Meet C2-C3

GEMKHANA 2021

Section: N-10.5

Material: Any Clear Quartz

Facets: 22 + 6 girdle = 28 (Crown 16 Pavilion 6)

Meets: 19 (Crown 12 Pavilion 7)

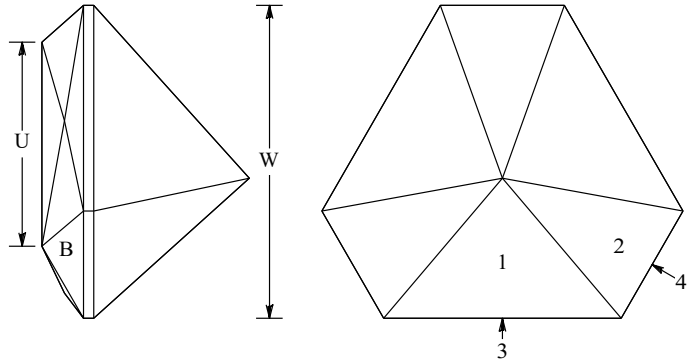
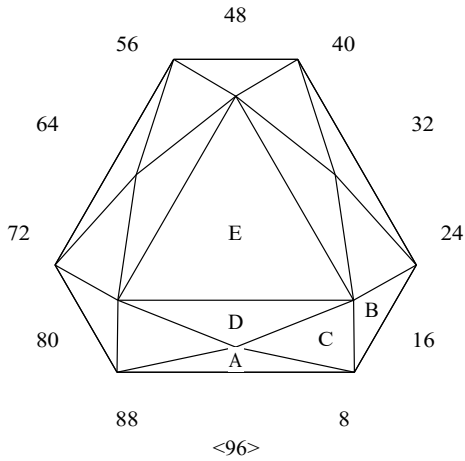

DOUBLE TRIPLE

By Robert H Long

Angles for R.I. = 1.540

22 + 6 girdles = 28 facets

3-fold, mirror-image symmetry

96 index

$L/W = 1.155$ $T/W = 0.753$ $U/W = 0.652$

$P/W = 0.497$ $C/W = 0.133$

$Vol./W^3 = 0.239$

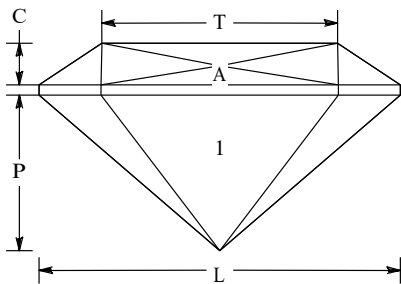

PAVILION

1	48.00°	96-32-64	Form PCP
2	42.00°	16-48-80	Meet PCP
3	90.00°	96-32-64	Set stone size
4	90.00°	16-48-80	Level girdle

CROWN

A	37.00°	96-32-64	Set girdle thickness
B	48.50°	16-48-80	Level girdle
C	30.00°	01-31-33-63-65-95	Meet A-B at girdle
D	25.69°	96-32-64	Meet A-C
E	0.00°	Table	Meet B-C

GEMKHANA 2021

Section: N-10.6

Material: MM Coloured Spinel

Facets: 45 + 8 Girdle = 53 (Crown = 29 Pavilion = 16)

Meets: 25 (Crown = 16 Pavilion = 9)

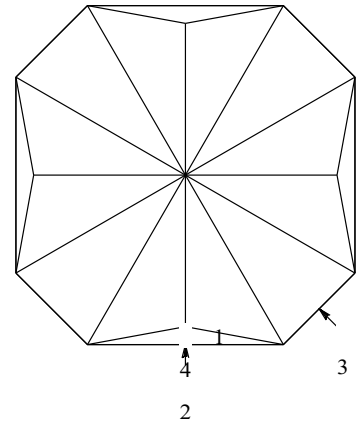
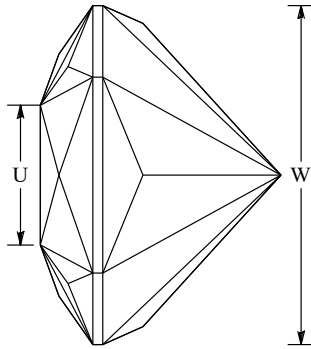
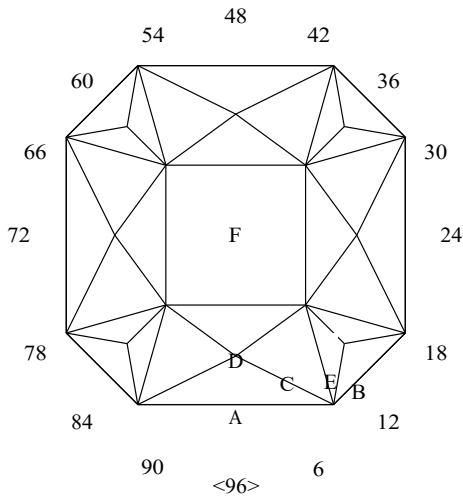

USFG-1

Author Unknown

Angles for R.I. = 1.720

45 + 8 girdles = 53 facets

4-fold, mirror-image symmetry

96 index

$L/W = 1.000$ $T/W = 0.412$ $U/W = 0.412$

$P/W = 0.526$ $C/W = 0.155$

$Vol./W^3 = 0.281$

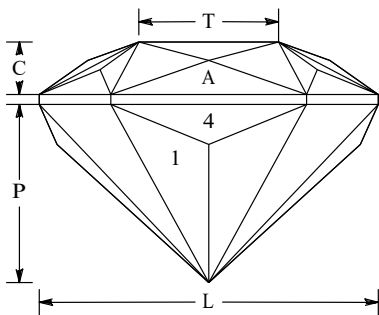

PAVILION

1	43.30°	04-12-20-28- 36-44-52-60- 68-76-84-92	Form TCP
2	90.00°	96-24-48-72	Set Stone Size
3	90.00°	12-36-60-84	Meet P2
4	66.00°	96-24-48-72	Level Girdle Line

CROWN

A	35.00°	96-24-48-72	Set Girdle Thickness
B	35.00°	12-36-60-84	Level Girdle
C	27.00°	03-21-27-45- 51-69-75-93	Meet A-B
D	20.00°	96-24-48-72	Meet A-C-C
E	27.66°	08-16-32-40- 56-64-80-88	Meet B-C @ Girdle
F	0.00°	Table	

GEMKHANA 2021

Section:- J-10.7

Material:- Any Clear Quartz

Facets:- 41 + 8 Girdle = 49 (Crown 17 Pavilion 24)

Meets:- 41 (Crown 16 Pavilion 25)

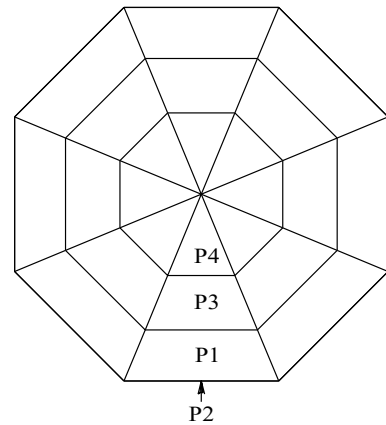
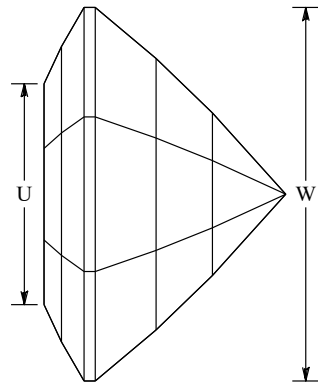
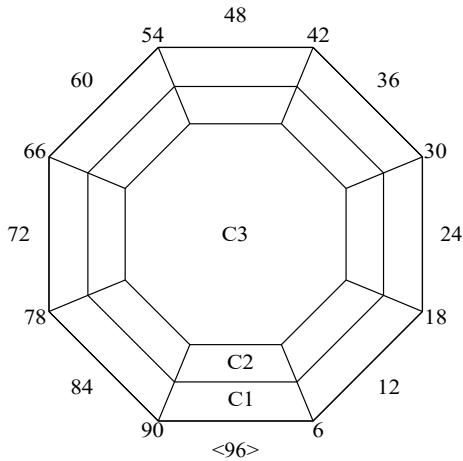

JUNIOR ASHER CUT

Angles for R.I. = 1.540

41 + 8 girdles = 49 facets

8-fold, mirror-image symmetry

96 index

$L/W = 1.000$ $T/W = 0.591$ $U/W = 0.591$

$P/W = 0.510$ $C/W = 0.107$

$Vol./W^3 = 0.239$

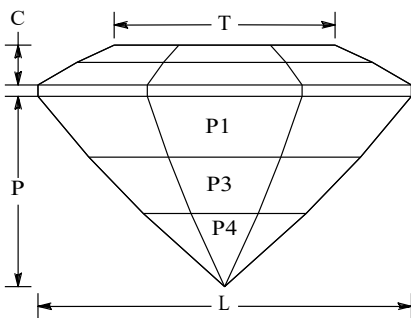

PAVILION

P1	50.00°	96-12-24-36-48-60-72-84
P2	90.00°	96-12-24-36-48-60-72-84
P3	46.00°	96-12-24-36-48-60-72-84
P4	42.00°	96-12-24-36-48-60-72-84

Form TCP

Shape and size stone

Set to size required

Set to equal size & form PCP

CROWN

C1	30.00°	96-12-24-36-48-60-72-84
C2	25.00°	96-12-24-36-48-60-72-84
C3	0.00°	Table

Set girdle thickness

Set to required size

Equal sizes

GEMKHANA 2021

ROBIN

Section: O-11.1

Material: MM Coloured Cubic Zirconia

Facets: 56 + 8 Girdle = 64 (Crown 32 Pavilion 24)

Meets: 34 (Crown 25 Pavilion 9)

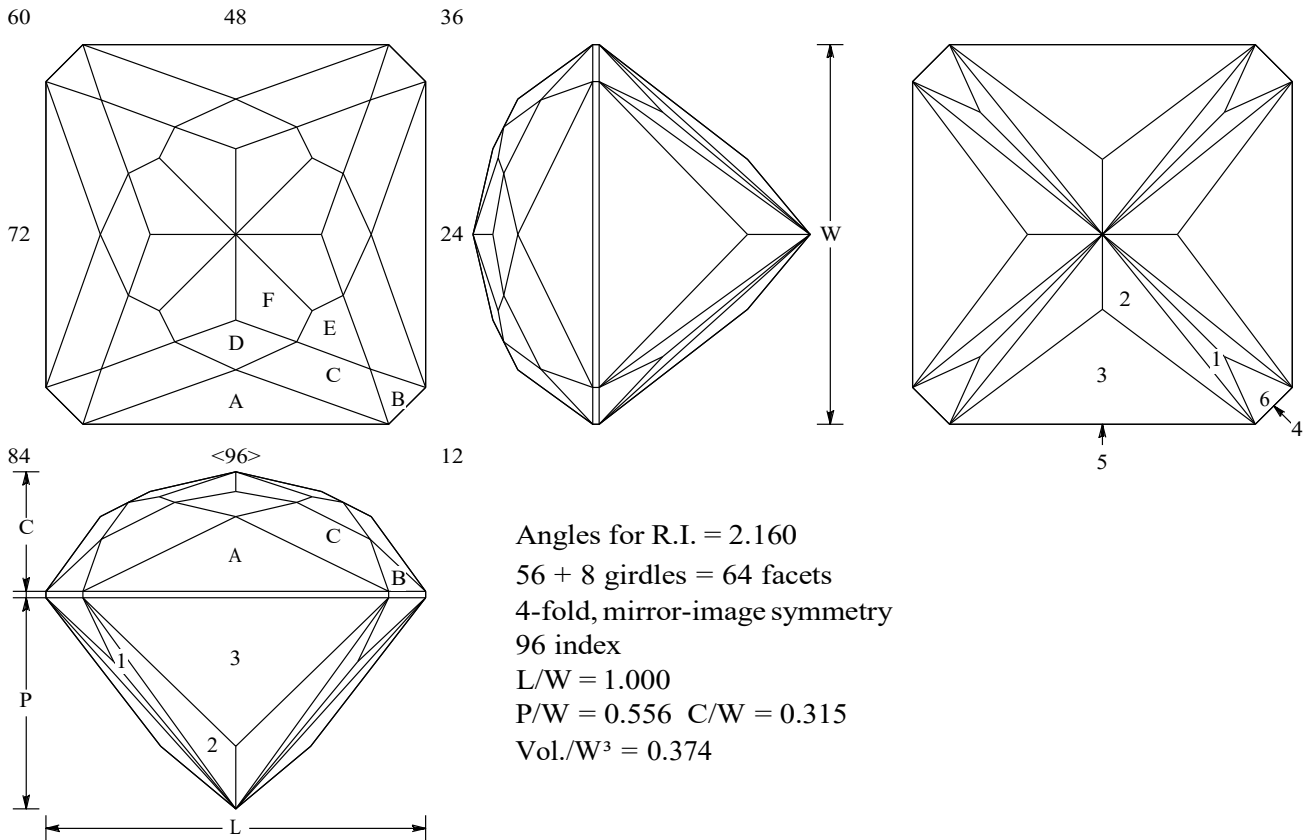

PAVILION

1	41.00°	09-15-33-39- 57-63-81-87	Cut to PCP
2	42.06°	06-18-30-42- 54-66-78-90	Meet 1 at PCP
3	52.29°	96-24-48-72	Cut so meet point 1,2,3 is at girdle
4	90.00°	12-36-60-84	Meet 1,2,3 & level girdle
5	90.00°	96-24-48-72	Meet 1,2,3,4
6	42.50°	12-36-60-84	Meet 1,2,3,4,5 & level girdle

CROWN

A	54.00°	96-24-48-72	Set girdle thickness-form TCP
B	45.00°	12-36-60-84	Meet A,4,5,level girdle - new TCP
C	42.00°	03-21-27-45- 51-69-75-93	Meet A,B,4,5 new TCP
D	26.63°	96-24-48-72	Meet A,C,C -new TCP
E	27.40°	12-36-60-84	Meet B,C,C
F	14.06°	06-18-30-42- 54-66-78-90	Meet C,D,E & create PCP

GEMKHANA 2021

Section:- I-11.2

Material:- MM Coloured Spinel

Facets:-60 + 8 Girdle (Crown 42 Pavilion 18)

Meets:- 32 (Crown 25 Pavilion 7)

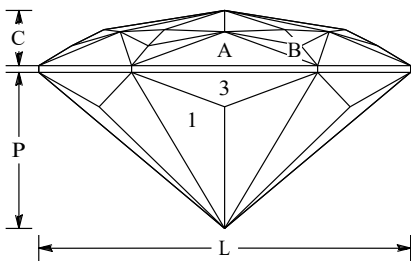
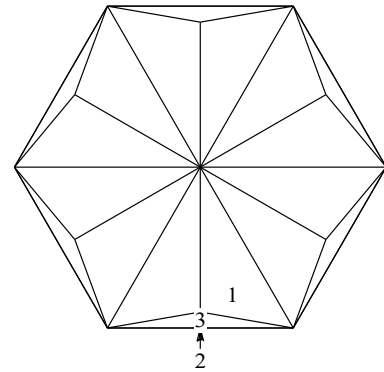
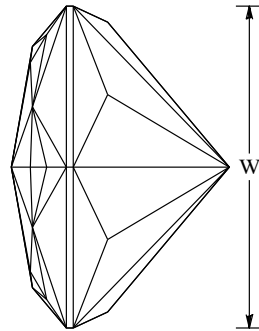
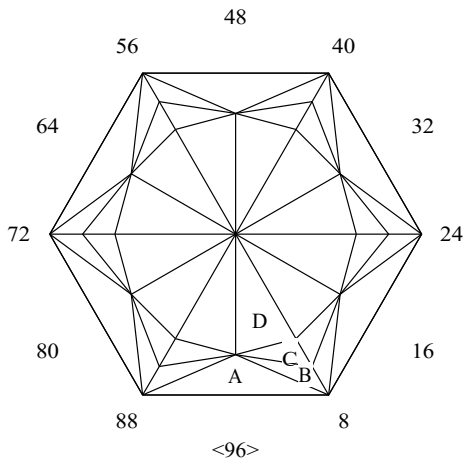

MINI HEXAGON APEX

Author Norman Steele

Angles for R.I. = 1.720

60 + 6 girdles = 66 facets

6-fold, mirror-image symmetry

96 index

L/W = 1.155

P/W = 0.485 C/W = 0.171

Vol./W³ = 0.254

PAVILION

1	41.00°	04-12-20-28-36-44- 52-60-68-76-84-92	Cut of facets to PCP
2	90.00°	96-16-32-48-64-80	Set stone size
3	65.00°	96-16-32-48-64-80	Meet P1-P1 at corners

CROWN

A	40.00°	96-16-32-48-64-80	Set girdle thickness
B	33.00°	02-14-18-30-34-46- 50-62-66-78-82-94	Meet C1-C1-girdle
C	28.00°	03-13-19-29-35-45- 51-61-67-77-83-93	Meet C2-C1-C2
D	10.00°	01-15-17-31-33-47- 49-63-65-79-81-95	Meet C1-C2-C3

GEMKHANA 2021

Section:- N-11.3

Material:- MM Coloured Cubic Zirconia

Facets:- 56 + 8 girdle = 64 (Crown 24 Pavilion 32)

Meets:- 46 (Crown 25 Pavilion 21)

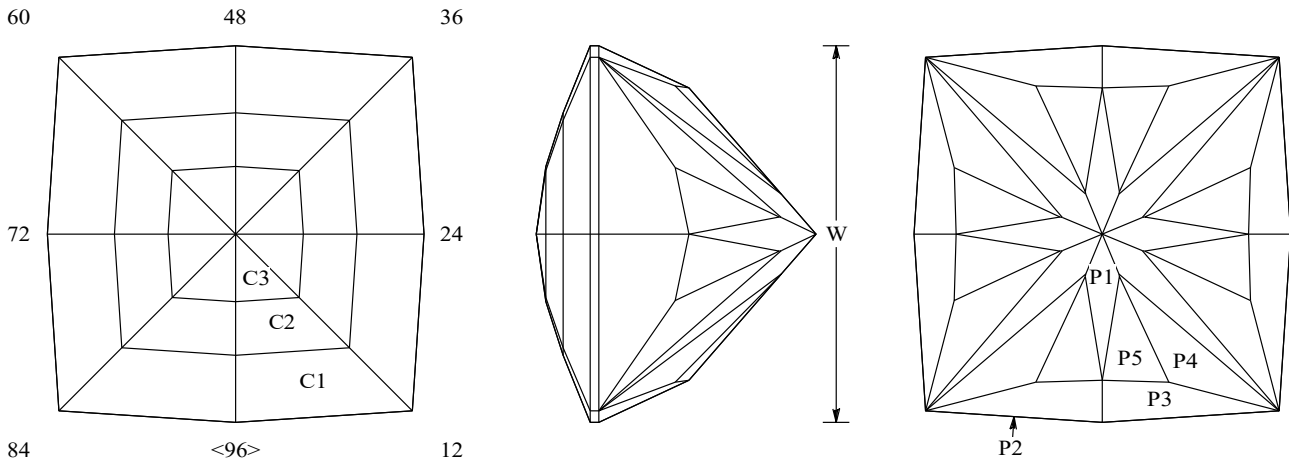

OLD MINE BARION

Angles for R.I. = 2.160

56 + 8 girdles = 64 facets

4-fold, mirror-image symmetry

96 index

L/W = 1.000

P/W = 0.577 C/W = 0.143

Vol./W³ = 0.304

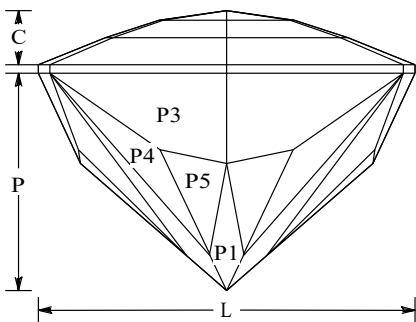

PAVILION

P1	41.00°	96-12-24-36-48-60-72-84	Form TCP
P2	90.00°	01-23-25-47-49-71-73-95	Set Stone Size
P3	65.00°	01-23-25-47-49-71-73-95	Level Girdle
P4	42.00°	09-15-33-39-57-63-81-87	Meet P3-P3 @ girdle
P5	42.50°	03-21-27-45-51-69-75-93	Meet P3-P4

CROWN

C1	22.00°	01-23-25-47-49-71-73-95	Set Girdle Thickness
C2	18.00°	01-23-25-47-49-71-73-95	Cut to equal size
C3	8.00°	01-23-25-47-49-71-73-95	Cut to equal size