

GEMKHANA 2013 COMPETITION SCHEDULE LEVEL 3

Judging will be in accordance with the AFLACA Competition and Judging Manual issue No 7
Please refer to Point 1.1 of “Conditions of Entry” included with this Schedule.

O=OPEN I=INTERMEDIATE N=NOVICE J=JUNIOR TR=TROPHY
**ENTRY FEE = \$1.00 per entry for 1st ten (10) entries, thereafter FREE

STANDARD CABOCHONS (Section 1A): Specified Size 30x22mm.

- O – 1A - Standard Cabochon – C/S – AGATE
- I - 1A(1) Standard Cabochon – C/S – AGATE
- N – 1A(2) - Standard Cabochon – C/S – AGATETR
- J – 1A(3) - Standard Cabochon – C/S – OWN CHOICE MATERIAL

FANCY, DOUBLE STANDARD & DOUBLE FANCY CABOCHONS:

Min Dimension to be not less than 30mm on the longest dimension across the outline shape.

- O – 1B - Fancy Cabochon – C/S – PETRIFIED WOOD
- I - 1B(1) Fancy Cabochon – C/S - PETRIFIED WOOD
- N – 1B(2) - Fancy Cabochon – C/S - PETRIFIED WOOD
- J – 1B(3) - Fancy Cabochon – C/S - PETRIFIED WOOD
- O – 1B(4) - Fancy Cabochon – A/A – LACE AGATE
- I – 1B(5) - Fancy Cabochon – A/A – LACE AGATE
- N – 1B(6) - Fancy Cabochon – A/A – LACE AGATE
- J – 1B(7) - Fancy Cabochon – A/A - LACE AGATE
- O – 2A - Double Standard Cabochon – C/S – OBSIDIANTR
- I - 2A(1) Double Standard Cabochon – C/S - OBSIDIAN
- N – 2A(2) - Double Standard Cabochon – C/S - OBSIDIAN
- J – 2A(3) - Double Standard Cabochon – C/S - OBSIDIAN
- O – 2B - Double Fancy Cabochon – A/A – OWN CHOICE MATERIAL
- I – 2B(1) - Double Fancy Cabochon – A/A – OWN CHOICE MATERIAL
- N – 2B(2) - Double Fancy Cabochon – A/A – OWN CHOICE MATERIAL

FREEFORMS: Must not pass through 15mm hole.

- O – 3 - Freeform – C/S – OWN CHOICE MATERIAL
- I – 3(1) - Freeform – C/S – OWN CHOICE MATERIAL
- N – 3(2) - Freeform – C/S - OWN CHOICE MATERIAL
- J – 3(3) - Freeform – C/S - OWN CHOICE MATERIAL

FREEFORM OPAL: Must not pass through a 10mm hole.

- O – 3(4) - Freeform – C/S – Specified Material – SOLID OPAL
- N – 3(5) - Freeform – C/S – Specified Material – SOLID OPAL

OPAL SECTIONS: Must not pass through a 10mm hole.

- O – 4B - Opal Doublet – Domed Top
- N – 4B(1) - Opal Doublet – Domed Top
- O – 4C - Opal Triplet
- N – 4C(1) - Opal Triplet

CARVINGS: Hardness under 4 & Min size 50mm on longest dimension (excluding base or mount). Max is 300mm (including base or mount). NOTE: All carvings to be accompanied by a neat label, naming material used. (Label will not be judged).

- O – 5A - Carving – 3 dimensional
 I – 5A(1) - Carving – 3 dimensional
 N – 5A(2) - Carving – 3 dimensional
 J – 5A(3) - Carving – 3 dimensional

Hardness 4 and over

- O – 5A(4) - Carving – 3 dimensional.....TR
 I – 5A(5) Carving – 3 dimensional
 N – 5A(6) Carving – 3 dimensional
 J – 5A(7) - Carving – 3 dimensional

CARVINGS (con't) Any Hardness

- O – 5B - Carving – in Relief
 N – 5B(1) - Carving – in Relief

SCRIMSHAW: Min size 60mm on longest dimension, excluding base. Max 300mm incl. base.

- O – 6 - Scrimshaw
 N – 6(1) - Scrimshaw

FACET CUTS: Min size 6mm on shortest axis of outline shape unless otherwise specified.

**(NB: All Facet Cuts to be cut as per diagrams and specifications supplied).
 (REFER TO PARAGRAPH 6 OF "CONDITIONS OF ENTRY" FOR TROPHY DETAILS)**

- O - 8A - Standard Brilliant – continuous girdle – COLOURLESS TOPAZ.....TR
 I - 8A(1) - Standard Brilliant – continuous girdle – COLOURLESS TOPAZ
 N – 8A(2) - Standard Brilliant – continuous girdle – COLOURLESS TOPAZ.....TR
 O - 8B - Standard Brilliant – faceted girdle – NATURAL COLOURED QUARTZ.....TR
 I - 8B(1) - Standard Brilliant – faceted girdle – NATURAL COLOURED QUARTZ
 N - 8B(2) - Standard Brilliant – faceted girdle – NATURAL COLOURED QUARTZ.....TR
 J - 8B(3) - Standard Brilliant – faceted girdle – NATURAL COLOURED QUARTZ
 O - 9A - Standard Oblong Step Cut with cut corners –SMOKEY QUARTZTR
 I - 9A(1) - Standard Oblong Step Cut with cut corners –SMOKEY QUARTZ
 N - 9A(2) - Standard Oblong Step Cut with cut corners –SMOKEY QUARTZTR
 O - 10 - Modified Standard Cut – "Rectangle Cushion Shallow Pavilion" – M/M CORUNDUM
 I – 10(1) - Modified Standard Cut – "Rectangle Cushion Shallow Pavilion" – M/M CORUNDUM
 N - 10(2) - Modified Standard Cut – "Novice Cushion Triangle – M/M CUBIC ZIRCONIA
 J - 10(3) - Modified Standard Cut – "Old Mine" – M/M/ CORUNDUM
 O - 11 - Fancy Cut – "Park Lane Cut" – M/M/ CUBIC ZIRCONIA
 I - 11(1) - Fancy Cut – "Park Lane Cut" – M/M/ CUBIC ZIRCONIA
 N - 11(2) - Fancy Cut – "Park Lane Cut" – M/M/ CUBIC ZIRCONIA

TUMBLER STONES: Must not pass through a 15mm hole. (NB: Refer to Special Condition 5.4)

- O – 12A - Tumbled Stones – Preformed Group of 3 – Each to be a different species or variety
 O – 12B - Tumbled Stones – Natural Group of 3 – Each to be a different species or variety

POLISHED FACE: Min. size 50mm short axis. Max 300mm on any dimension.

- O – 13 - Polished Face – FLAT surface – A/A
 O – 14 - Polished Face – CURVED surface – A/A

GEM TREES: Must not fit in 150mm cube – Must fit in 300mm cube.

- O – 16 - Gem Tree(s) – Material may be natural, man-made or natural organic
 N – 16(1) - Gem Tree(s) – Material may be natural, man-made or natural organic

NOVELTY GEMCRAFT: Min size 80mm on longest dimension (excluding base or mount). Max is 300mm (including base or mount).

- O – 17 - Novelty Gemcraft
 N – 17(1) - Novelty Gemcraft

HAND FABRICATED JEWELLERY & WIRE WRAPPED JEWELLERY:

- O – 18A - H/Fabricated Jewellery not intended to include Lapidary, Fossil or Mineral
- N – 18A(1) - H/Fabricated Jewellery not intended to include Lapidary, Fossil or Mineral
- O – 18B - H/Fabricated Jewellery with Lapidary item cut/set by entrant
- I – 18B(1) - H/Fabricated Jewellery with Lapidary item cut/set by entrant
- N – 18B(2) - H/Fabricated Jewellery with Lapidary item cut/set by entrant
- O – 18C - H/Fabricated Jewellery with natural Fossil or Mineral set by entrant
- O – 18E - Wire Wrapped Jewellery with Lap., Fossil or Mineral item/s prepared and set by entrant
- I – 18E(1) - Wire Wrapped Jewellery with Lap., Fossil or Mineral item/s prepared and set by entrant
- N – 18E(2) - Wire Wrapped Jewellery with Lap., Fossil or Mineral item/s prepared and set by entrant
- O – 18F - Wire Wrapped Jewellery with Commercial Lapidary item/s set by entrant
- N – 18F(1) - Wire Wrapped Jewellery with Commercial Lapidary item/s set by entrant

CAST JEWELLERY: Using patterns/moulds made by entrant.

- O – 19A - Cast Jewellery not intended to include Lapidary, Fossil or Mineral
- N – 19A(1) - Cast Jewellery not intended to include Lapidary, Fossil or Mineral

Using Natural Objects as Patterns

- O - 20A - Cast Jewellery using Natural Objects as Patterns.....TR
- N - 20A(1) - Cast Jewellery using Natural Objects as Patterns.
- O – 20E - Cast Jewellery without Lap. etc. item/s – METAL CLAY (See Special Conditions 5.7)
- N – 20E(1) - Cast Jewellery without Lap. etc. item/s – METAL CLAY (See Special Conditions 5.7)

Using Commercial Wax models or Patterns

- O – 21A - Cast Jewellery not intended to include Lapidary, Fossil or Mineral
- N – 21A(1) - Cast Jewellery not intended to include Lapidary, Fossil or Mineral.....TR
- O – 21B - Cast Jewellery with Lapidary item(s) cut/set by entrant
- N – 21B(1) - Cast Jewellery with Lapidary item(s) cut/set by entrant
- O – 21C - Cast Jewellery with Natural Fossil or Mineral set by entrant
- N – 21C(1) - Cast Jewellery with Natural Fossil or Mineral set by entrant
- O – 21D - Cast Jewellery with Commercial Lapidary item(s) set by entrant
- N – 21D(1) - Cast Jewellery with Commercial Lapidary item(s) set by entrant
- O – 21E - Cast Jewellery (METAL CLAY) with Commercial Lapidary item(s) set by entrant (See Special Conditions 5.7)
- N – 21E(1) - Cast Jewellery (METAL CLAY) with Commercial Lapidary item(s) set by entrant (See Special Conditions 5.7)

ENAMELLED JEWELLERY:

- O – 24A - Enamelled Jewellery in H/Fabricated setting – must be entrant’s own work
- O – 24B - Enamelled Jewellery in Cast setting – casting must be all made by entrant
- O – 24D - Enamelled Jewellery in Cast setting – commercial wax models to be used

COMMERCIAL MOUNT JEWELLERY:

- O – 25 - Commercial Mount Jewellery with Lapidary item(s) cut & set by entrant
- I – 25(1) - Commercial Mount Jewellery with Lapidary item(s) cut & set by entrant
- N – 25(2) - Commercial Mount Jewellery with Lapidary item(s) cut & set by entrant
- J – 25(3) - Commercial Mount Jewellery with Lapidary item(s) cut & set by entrant

ENAMELLING:

- O – 26A - Enamelled Jewellery in commercial mountTR
- N – 26A(1) - Enamelled Jewellery in commercial mount
- O – 26B - Enamelled Jewellery without mount
- N – 26B(1) - Enamelled Jewellery without mount
- O – 26C - Enamelled Non Jewellery – Functional or Non Functional
- N – 26C(1) - Enamelled Non Jewellery – Functional or Non Functional

SHOWCASE SECTIONS:

- O – 29B - Showcase General – Display - Lit
- N – 29B(1) - Showcase General – Display - Lit
- O – 29B(2) - Showcase General – CLUB - Display - Lit
- O – 31 - Showcase Novelty – OWN CHOICE (Title MUST be displayed) – LitTR

FOSSILS:

- O – 32A - Fossil – Non-display – Single AUSTRALIAN vertebrate
- I – 32A(1) - Fossil – Non-display – Single AUSTRALIAN vertebrate
- N – 32A(2) - Fossil – Non-display – Single AUSTRALIAN vertebrate
- J – 32A(3) - Fossil – Non-display – Single AUSTRALIAN vertebrate
- O – 32A(4) - Fossil – Non-display – Single OVERSEAS vertebrate
- I – 32A(5) - Fossil – Non-display – Single OVERSEAS vertebrate
- N – 32A(6) - Fossil – Non-display – Single OVERSEAS vertebrate
- J – 32A(7) - Fossil – Non-display – Single OVERSEAS vertebrate
- O – 32B - Fossil – Non-display – Group of 3 PLANTS – ANY LOCALITY
- I – 32B(1) - Fossil – Non-display – Group of 3 PLANTS – ANY LOCALITY
- N – 32B(2) - Fossil – Non-display – Group of 3 PLANTS – ANY LOCALITY
- J – 32B(3) - Fossil – Non-display – Group of 3 PLANTS – ANY LOCALITY

MINERALS AND MINERAL SHOWCASES: Miniature or Cabinet size unless otherwise specified.

- O – 34A - Mineral – Non display – Single OVERSEAS Specimen
- N – 34A(1) - Mineral – Non display – Single ANY LOCALITY Specimen
- O – 34A(2) - Mineral – Non display – Single AUSTRALIAN Specimen
- N – 34A(3) - Mineral – Non display – Single AUSTRALIAN Specimen
- O – 34B - Minerals – Non display - Group of 3 – ANY LOCALITY – Miniature Size
- N – 34B(1) - Minerals – Non display - Group of 3 – ANY LOCALITY – Miniature Size
- O – 37B - Mineral Showcase – Display - Lit

FLORAL & ARTISTRY IN ROCK:

NB: These Sections will be judged and awards given, however, points will not be allocated towards the ‘Most Successful Competitor’ or the ‘Most Successful Club’ trophies.

- O – 39 - Stone & Floral Arrangement - FORMAL
- O – 40 - Stone & Floral Arrangement – FORMAL REFLECTIONS
- O – 41 - Stone & Floral Arrangement - INFORMAL
- O – 42 - Artistry in Rock

2013 GEMKHANA COMPETITION SCHEDULE'S CONDITIONS OF ENTRY

1. INTRODUCTION

- 1.1. This is a Level 3 Competition, and will be conducted in accordance with the AFLACA Competitor & Judging Manual Issue No 7, April 2006, (to be referred to as "Manual No 7" for the purposes of this Schedule), unless otherwise stated in the list of Special Conditions (see part 5 of these conditions).
- 1.2. All competitors are advised to familiarize themselves with all the "Conditions for Competitors" in Manual No 7 (particularly pages 5 -13).
- 1.3. Inquiries and Correspondence relating to these conditions should be directed to:
GEMKHANA 2013 COMPETITION COMMITTEE
257 Box Rd
Sylvania NSW 2224
Phone inquiries to John Mackenzie: (02) 9522-7422 or 0425 287 432.

2. GENERAL CONDITIONS OF ENTRY

- 2.1. (i) The **OFFICIAL ENTRY FORM** or copy thereof must be used and
(ii) A stamped, self addressed envelope must be included if acknowledgement of entry form/fees is required.
- 2.2. **FEES:** \$1 per entry for the first ten (10) entries (thereafter free) and all fees **must** accompany the Official Entry Form.
- 2.3. All entries not being collected at the GEMKHANA in person must be accompanied by a \$10 cheque/money order/postal note to cover the cost of return of entries by mail.
- 2.4. **NB: All cheques MUST be made payable to GEM & LAPIDARY COUNCIL OF NSW Inc.**
- 2.5. A maximum of two (2) entries per person per section is allowed, except in Showcase sections (refer to F4.1(b), page 89; G6.1(b), page 100 and H7.1(b) page 115 in Manual No 7 for details).
- 2.6. ALL **ENTRY FORMS AND FEES** MUST BE IN THE HANDS OF THE GEMKHANA 2013 COMPETITION COMMITTEE BY FRIDAY, 9th AUGUST, 2013. **No exceptions will be considered.** (Send to the address above).
- 2.7. Juniors must be under the age of 16 years on Friday, 9th August, 2013.
- 2.8. Medals will be awarded to 1st, 2nd and 3rd placed entries and/or Highly Commended. At the GEMKHANA 2013 Competition Committee's discretion, where there are few entries in a Novice or Intermediate section, awards MAY be nominated as 'Special Awards' and will not affect Entrants eligibility in future competitions.
- 2.9. Whilst every care will be taken, the GEMKHANA 2013 Competition Committee **will not** accept any responsibility for any loss or damage of Competitive or Non Competitive entries that may occur in transit or whilst in the possession of the GEMKHANA 2013 Competition Committee.
- 2.10. The GEMKHANA 2013 Competition Committee regrets it is unable to carry insurance cover on entries/exhibits whilst in their possession. We strongly advise competitors and exhibitors to arrange their own insurance cover.

3. COMPETITION ENTRIES – (Reception and Return of Entries)

- 3.1. Sections 1 to 4, 8 to 14, 18 to 26 will be judged before the GEMKHANA 2013.
- 3.2. The GEMKHANA 2013 Competition Committee reserves the right to transfer any entry into its correct section, if, in their opinion, the entry has been entered into the wrong section.

- 3.3. **ALL POSTAL ENTRIES:** Entries in the above sections can be mailed to the above address and **MUST** be received by **FRIDAY, 16th AUGUST, 2013. No exceptions will be considered.** Entrants who require their entries to be returned by post after the GEMKHANA 2013 are asked to clearly indicate this on their entry form.
- 3.4. **ENTRIES IN PERSON:** Entries mentioned in Section 3.1 (above) can be delivered to the GEMKHANA 2013 Competition Committee at the Clubrooms of Port Hacking Lapidary Club Inc, Warburton Lane (off Warburton St), Gympie, **between 10am & 1pm on SATURDAY, 17th AUGUST, 2013.** (Clubroom phone no. (02) 9526-1106).
- 3.5. **JUDGING OF ENTRIES:**
- 3.5.1. Sections 5, 6, 16, 17, 29, 31, 32, 34, 37 and 39-42 will be judged **at** the GEMKHANA 2013. Entries in these sections will be accepted by the GEMKHANA 2013 Competition Committee in the Exhibition Hall **from 1pm – 5pm on FRIDAY, 4th October, 2013, or BY PRIOR ARRANGEMENT ONLY between 8am & 9am SATURDAY 5th October, 2013.** Please contact the Competition Chairman (John Mackenzie) on 0425 287 432 to make such arrangements. (These times also apply to Showcases which must be in position and dressed by these times).
- 3.5.2. Entries in Sections 29, 31, 32, 34 & 37 must be set-up and ready, in the Exhibition Hall, before they are judged at GEMKHANA 2013. Judging which will take place at **9am, SATURDAY, 5th October, 2013.**
- 3.5.3. Sections 39, 40, 41 & 42 (STONE & FLORAL ARRANGEMENTS & ARTISTRY IN ROCK): Entry forms will be accepted by the GEMKHANA 2013 Competition Committee up until **5:00pm, Friday, 4th October, 2013** and entries must be in place for judging by **8am SATURDAY, 5th October, 2013.**
- 3.6. **Access to the Exhibition Hall** (for setting up of entries) is yet to be arranged but anticipate it will be from 9am to 5pm, Friday, 4th October 2013 and 8am to 9am, Saturday, 5th October, 2013.
- 3.7. **RETURN OF ENTRIES:**
- 3.7.1 All entries (other than postal) must be collected on **MONDAY, 7th October, 2013**, in the Exhibition Hall **between 2pm & 3pm.** It is the responsibility of the Entrant to check their entries prior to leaving the hall.
- 3.7.2 **Postal entries & their Judging Sheets** will be returned, by mail, within fourteen (14) days.
PLEASE NOTE: All due care will be taken, however, the GEMKHANA 2013 Competition Committee accepts no responsibility if any loss and/or damage occurs.
- 3.8 **JUDGING SHEETS:** Will be available for collection, in the Exhibition Hall, **between 10am & noon, SUNDAY, 6th October, 2013.** Judging Sheets not collected during this time will be returned with the actual entries.

4 COMPETITION DIVISIONS:

- 4.1 The GEMKHANA 2013 Competition Committee strongly advises all entrants to read Section B4 "Competition Divisions" (page 6) in the Competitor & Judging Manual No 7, April 2006 to understand the eligibility criteria for entering the various divisions of a GEMKHANA.

5 SPECIAL CONDITIONS:

- 5.1 **SIZES AND TOLERANCES:** Where an entry does not conform to the size conditions in this Schedule or Manual No 7 it will be ruled ineligible and not judged. Refer to section definitions in this Schedule and Manual No 7 for allowable tolerances.
- 5.2 **CARVING:** SECTION 5: Each entry must have a label which best describes the exhibit for the viewers' interest. Labels will not be judged.
- 5.3 **FACET ENTRIES:** SECTIONS 8 TO 11: materials must be named on the box in which it is entered. If material is not named, or is incorrectly named, the entry will be ruled ineligible. (See page 43, Pts D11.3(d) & D11.3(e) of Manual No 7).

- 5.4 **TUMBLER STONES:** SECTIONS 12A & 12B: Please see page 19 (D2.2) and page 55 (D12.1 and D12.2) of Manual No 7 for definitions for these sections.
- 5.5 **JEWELLERY:** SECTIONS 18 to 26: Competitors should carefully read Part E of Manual No 7 in relation to all Jewellery Sections.
- 5.6 **WIRE WRAPPED JEWELLERY:** Sections O18F, N18F(1), O21D, N21D(1) O21E & N21E(1): Beads may be used as an accompaniment to a cabochon or any other natural lapidary item or by themselves in jewellery in these sections. Beads must be in Natural Lapidary Material or Natural Organic Material as defined in D2.2 and D2.4 on page 19 of Manual No 7.
- 5.7 **METAL CLAY:** SECTIONS O20E, N20E(1) O21E & N21E(1): Metal Clay is not a recognized AFLACA group, but will be judged using the applicable judging sheets on pages 72 & 75 of Manual No 7.
- 5.8 **SHOWCASES:** SECTIONS 29, 31 & 37: Definition of a Showcase size is covered by Rule F2 on page 87 of Manual No 7.
- 5.9 **NOVELTY SHOWCASE:** SECTION 31: Must contain a minimum of 20 lapidary and associated items owned by the entrant or immediate family (they do not have to be the work of the entrant). Title must be displayed in the showcase.

6 TROPHIES

- 6.1 An Award Ceremony will be conducted in the Exhibition Hall, at **10am MONDAY, 7th October, 2013**, prior to the closing of GEMKHANA 2013. This will include the announcements of Perpetual Trophy winners, presentation of Annual and Keepers Trophies and the announcements of the Most Successful Competitor and Most Successful Club.

SPECIAL ONE-OFF TROPHIES

- SECTION N - 1A(2) – Standard Cabochon – AGATE.
SECTION O - 5A(4) – Carving 3-Dimensional – Hardness 4 or over.
SECTION N - 21A(1) – Cast Jewellery not intended to include Lapidary, Fossil or Mineral.

THE JOAN BALL TROPHIES

- SECTION O-26A – Enamelled Jewellery in Commercial Mount.
SECTION O-31 – Showcase Novelty – ‘OWN CHOICE’

THE ALAN COULTON TROPHY

- SECTION O-20A – Cast Jewellery using Natural Objects as Patterns

PERPETUAL TROPHIES

- THE BORIS NOVIC TROPHY** - for the Competitor with the highest score in Open section O-2A, Double Standard Cabochon – C/S Obsidian.
- THE DICK MOPPET TROPHY - NOVICE** - for the Novice competitor with the highest aggregate points for two (2) faceted stones, both standard cuts, one shall be STANDARD BRILLIANT and the other a STANDARD STEP CUT. Please note: competitors entered in Sections N-8A(2), N-8B(2), & N-9A(2) automatically compete for this trophy.
- THE DICK MOPPET TROPHY - OPEN** - for the Open competitor with the high aggregate points for two (2) faceted stones, both standard cuts; one shall be STANDARD BRILLIANT and the other a STANDARD STEP CUT. Please note: competitors entered in Sections O-8A, O-8B & O-9A automatically compete for this trophy.
- THE ARTHUR ROFFY TROPHY** - for the “Best Mineral in Show” (as selected by the donor).
- THE FRANK LANDER TROPHY** - for the Most Successful Competitor.
(1st = 6 points; 2nd = 4 points; 3rd = 2 points; H/C = 1 point)
- THE FRANK HALL TROPHY** - for the Most Successful Club. Points are awarded as follows:
1st = 6 points; 2nd = 4 points; 3rd = 2 points; H/C = 1 point, plus 1 point for every entry gaining 75% of the score of the winning entry in that section.

NEW SOUTH WALES GEMKHANA 2013 COMPETITION
SECTION: 08A/18A(1)N8A(2)
STANDARD ROUND BRILLIANT WITH CONTINUOUS GIRDL
MATERIAL COLOURLESS TOPAZ
FACETS 58(CROWN 33,PAVIVION 24,GIRDLE 1)
MEETS 41(CROWN 24, PAVILION 17)

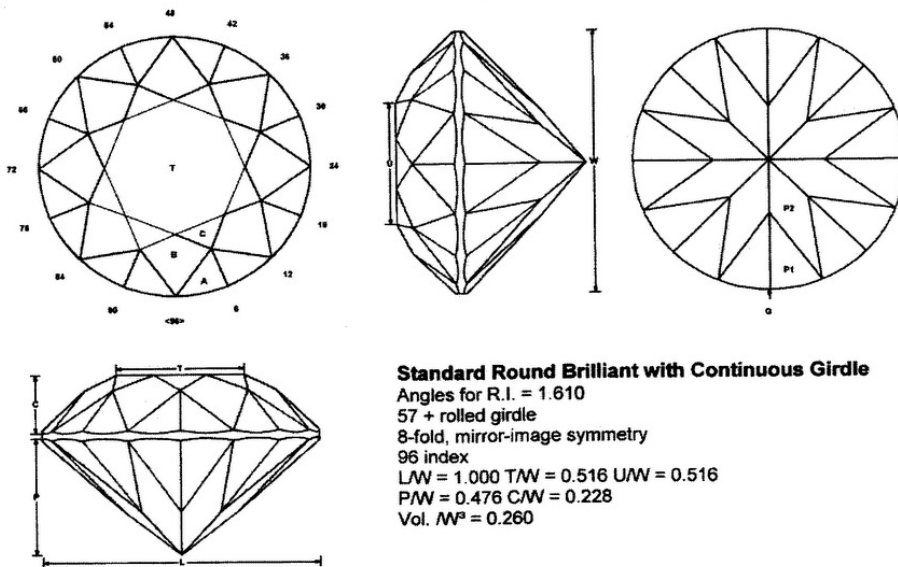

Standard Round Brilliant with Continuous Girdle
 Angles for R.I. = 1.610
 57 + rolled girdle
 8-fold, mirror-image symmetry
 96 index
 LW = 1.000 TW = 0.516 UW = 0.516
 PW = 0.476 CW = 0.228
 Vol. MW³ = 0.260

PAVILION

P1	43.00° 03-09-15-21-27-33-39-45-51-57-63-69-75-81-87-93	Cut to TCP
G	90.00°	Cut to size, "rolled girdle"
P2	41.00° 06-18-30-42-54-66-78-90	MP, 1 at girdle, form PCP

CROWN

A	37.00° 03-09-15-21-27-33-39-45-51-57-63-69-75-81-87-93	Set girdle width
B	30.00° 06-18-30-42-54-66-78-90	MP, A at girdle
C	19.00° 96-12-24-36-48-60-72-84	MP, A-B
T	0.00°	Table

NEW SOUTH WALES GEMKHANA 2013 COMPETITION
SECTION: O8B/I8B(1)N8B(2)/J8B(3)
STANDARD ROUND BRILLIANT WITH FACETED GIRDLE
MATERIAL-NATURAL COLOURED QUARTZ
FACETS:73(CRN 33, PAV 24, G 16) MEETS:57(CRN 32,PAV 25)

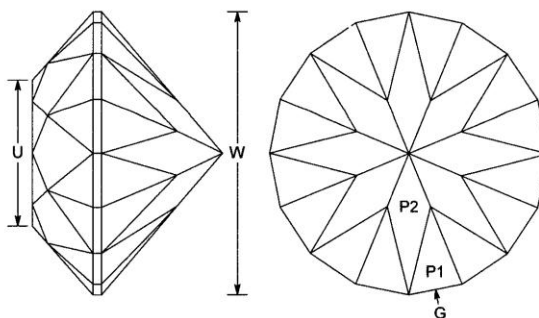
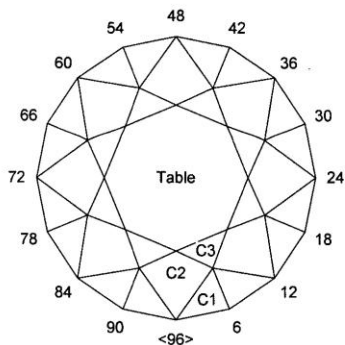

STANDARD BRILLIANT W/FACETED GIRDLE

Angles for R.I. = 1.540
 57 + 16 girdles = 73 facets
 8-fold, mirror-image symmetry
 96 index
 LW = 1.000 T/W = 0.516 U/W = 0.516
 P/W = 0.435 C/W = 0.218
 Vol./W³ = 0.241

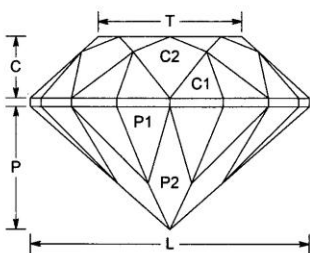

PAVILION

P1	43.00°	03-09-15-21-27-33-39-45-51-57-63-69-75-81-87-93	Cut to TCP
G	90.00°	03-09-15-21-27-33-39-45-51-57-63-69-75-81-87-93	Outline girdle
P2	41.00°	96-12-24-36-48-60-72-84	Cut to meet P1/G and make PCP

CROWN

C1	47.00°	03-09-15-21-27-33-39-45-51-57-63-69-75-81-87-93	Set girdle width and level girdle
C2	42.00°	96-12-24-36-48-60-72-84	Cut to meet C1/G/C1
C3	27.00°	06-18-30-42-54-66-78-90	Cut to meet C1/C2/C2/C1
Table	0.00°	Table	Cut to meet C3/C2/C3

NEW SOUTH WALES GEMKHANA 2013 COMPETITION
SECTION O9A/I9A(1)/N9A(2)
STANDARD OBLONG STEP CUT WITH CUT CORNERS
MATERIAL – SMOKY QUARTZ
FACETS: CROWN 25, GIRDLE 8, PAVILION 20.
MEETS: CROWN 25, PAVILION 20.

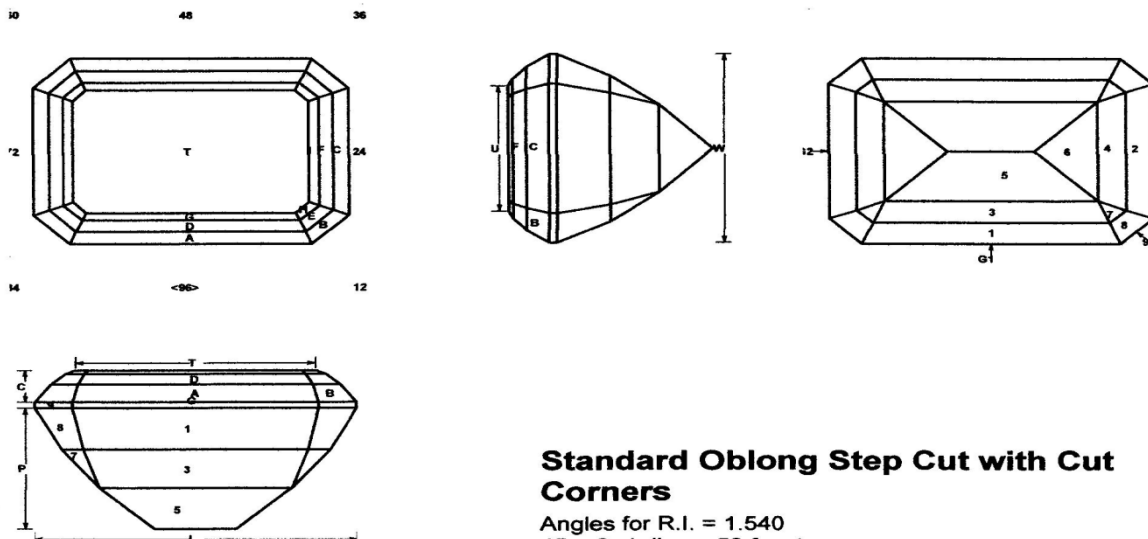

Standard Oblong Step Cut with Cut Corners

Angles for R.I. = 1.540
 45 + 8 girdles = 53 facets
 2-fold, mirror-image symmetry
 96 index
 $L/W = 1.250$ $T/W = 0.795$ $U/W = 0.545$
 $P/W = 0.521$ $C/W = 0.216$
 $Vol./W^3 = 0.458$

PAVILION

G1	90.00°	96-48	Size to width
G2	90.00°	24-72	Size to length
1	56.00°	96-48	Locate girdle
2	56.00°	24-72	Level girdle
3	49.00°	96-48	Cut as required
4	49.00°	24-72	MP, 1-2-3
5	42.00°	96-48	Cut as required
6	42.00°	24-72	MP, 3-4-5
7	49.00°	12-36-60-84	MP, 3-4-5-6
8	56.00°	12-36-60-84	MP, 1-3 & 2-4
9	90.00°	12-36-60-84	Level girdle

CROWN

A	55.00°	96-48	Set girdle width
B	55.00°	12-36-60-84	
C	55.00°	24-72	
D	42.00°	96-48	Estimate depth
E	42.00°	12-36-60-84	
F	42.00°	24-72	
G	27.00°	96-48	Estimate depth
H	27.00°	12-36-60-84	
I	27.00°	24-72	
T	0.00°	Table	Estimate depth

NEW SOUTH WALES GEMKHANA 2013 COMPETITION
SECTION O10 / I10(1)
RECTANGLE CUSHION SHALLOW PAVILION
MATERIAL – M/M CORUNDUM
FACETS: 69(CROWN 33, PAVILION 20, GIRDLE 16)
MEETS : 53(CROWN 32, PAVILION 21)

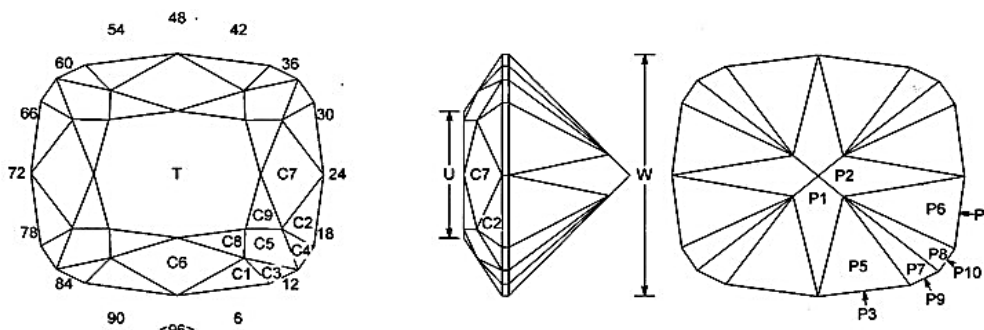

Rectangle Cushion Shallow Pavilion

Modified from 9.070 Square Cushion (Long and Steele)

John Broadfoot 2005

Angles for Corundum

Angles for R.I. = 1.760

53 + 16 girdles = 69 facets

2-fold, mirror-image symmetry

96 index

L/W = 1.179 T/W = 0.672 U/W = 0.525

P/W = 0.488 C/W = 0.154

Vol./W³ = 0.297

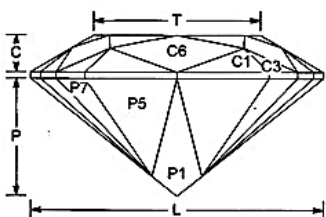

PAVILION

P1	44.29°	96-48	Cut to centreline
P2	39.62°	24-72	Cut to Centrepoint
P3	90.00°	02-46-50-94	Establish width - allow for crown height
P4	90.00°	22-26-70-74	Cut to meet P3 and form girdle line
P5	45.46°	02-46-50-94	Cut to form meetpoint with P1 and girdle
P6	40.51°	22-26-70-74	Cut to form meetpoint with P2 and girdle
P7	42.09°	07-41-55-89	Cut to meet with P1 and P2 towards culet
P8	39.39°	15-33-63-81	Cut to meet with P1 and P2 towards culet
P9	90.00°	07-41-55-89	Cut girdle to form line with P3
P10	90.00°	15-33-63-81	Cut girdle to form line with P4 and P9

CROWN

C1	40.44°	02-46-50-94	Establish girdle thickness and meet with line of P1 facets at the girdle
C2	36.71°	22-26-70-74	Establish girdle width and meet with line of P2 at girdle
C3	35.70°	07-41-55-89	Cut to meet C1 and line up with P5-P7 meetpoint
C4	34.62°	15-33-63-81	Cut to meet C2 and line up with P6-P8 meetpoint
C5	30.42°	10-38-58-86	Cut main to form meetpoint with C3-C4 at girdle
C6	33.00°	96-48	Cut main to form meetpoint with C1 facets at girdle
C7	31.36°	24-72	Cut main to form meetpoint with C2 facets at girdle
C8	24.67°	02-46-50-94	Cut to form meetpoint C1, C3, C5 and C6
C9	20.51°	20-28-68-76	Cut to form meetpoint with C2, C4, C5 and C7
T	0.00°	Table	Float table to form meetpoints with C8 and C9

The pavilion corner facets may need to be adjusted after completing the girdle to ensure the girdle line is continuous.

The C8 and C9 facets may need to be adjusted if the Table does not quite meet with these facets.

Alternatively, the C8 and C9 facets may be cut after the Table, adjusting the angles as needed.

C:\Program Files\GemCadWin\GemData\Rectangle\Rectangular Cushion Shallow Pavilion 1_20 Low Crown.gem

**NEW SOUTH WALES GEMKHANA 2013 COMPETITION
SECTION N10(2)**

MATERIAL--COLOURED MM CUBIC ZIRCONIA

FACETS: CROWN 16, GIRDLE 12, PAVILION 15.

MEETS: CROWN 18, PAVILION 15.

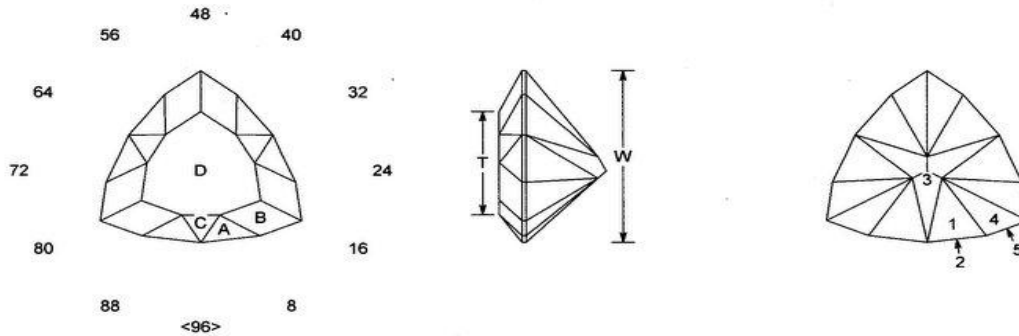

13.142 Novice Cushion Triangle

by Robert Strickland

Angles for R.I. = 2.160

31 + 12 girdles = 43 facets

3-fold, mirror-image symmetry

96 index

L/W = 1.009 T/W = 0.603 U/W = 0.599

P/W = 0.403 C/W = 0.113

Vol./W³ = 0.160

PAVILION

1	45.00°	02-30-34-62-66-94	Meet at TCP
2	90.00°	02-30-34-62-66-94	Size stone and level girdle
3	44.00°	96-32-64	Meet 1-1-2-2, make PCP
4	42.50°	06-26-38-58-70-90	Meet 2-2-3
5	90.00°	06-26-38-58-70-90	Level girdle

CROWN

A	37.82°	02-30-34-62-66-94	Set girdle to size
B	31.00°	06-26-38-58-70-90	Level girdle
C	35.37°	96-32-64	Meet girdle
D	0.00°	Table	Table

Modified for improved light return:

C:\DOCUME~1\JOHNMA~1\Desktop\FACETI~1\NOVICE~1.GEM

NEW SOUTH WALES GEMKHANA 2013 COMPETITION

SECTION J10(3)

OLD MINE MATERIAL M/M CORUNDUM

FACETS: 35(CRN 17, PAV 12, G 8)

MEETS : 29(CRN 16, PAV 13)

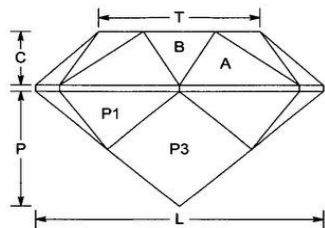
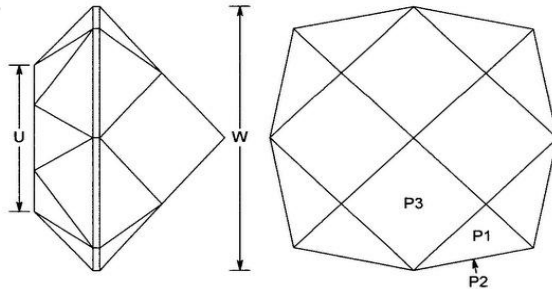
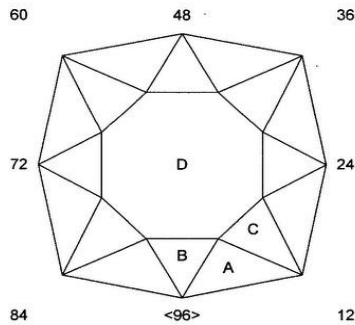

OLD MINE

Angles for R.I. = 1.760
 29 + 8 girdles = 37 facets
 4-fold, mirror-image symmetry
 96 index
 $L/W = 1.000$ $T/W = 0.562$ $U/W = 0.562$
 $P/W = 0.435$ $C/W = 0.204$
 $Vol./W^3 = 0.263$

PAVILION

P1	48.00°	03-21-27-45- 51-69-75-93	Cut to TCP
P2	90.00°	03-21-27-45- 51-69-75-93	Cut to size and level girdle
P3	41.00°	96-24-48-72	Cut to PCP and meet P1/P1 at girdle and P1/P1P3/P3

CROWN

A	47.00°	03-21-27-45- 51-69-75-93	Set girdle width and level girdle
B	43.00°	96-24-48-72	Cut to meet A/A at girdle
C	34.00°	12-36-60-84	Cut to meet A/A at girdle and at A/B, A/B meets.
D	0.00°	Table	Table, cut to meet A/B/C meets

C:\DOCUME~1\JOHNMA~1\Desktop\FACETI~1\OLDMIN~2.GEM

NEW SOUTH WALES 2013 GEMKHANA COMPETITION

SECTIONS: O11 / I11(1) / N11(2)

PARK LANE CUT

MATERIAL: M/M CUBIC ZIRCONIA

FACETS: 96(CROWN 40, PAVILION 40, GIRDLE 16)

MEETS: 58(CROWN 33, PAVILION 25)

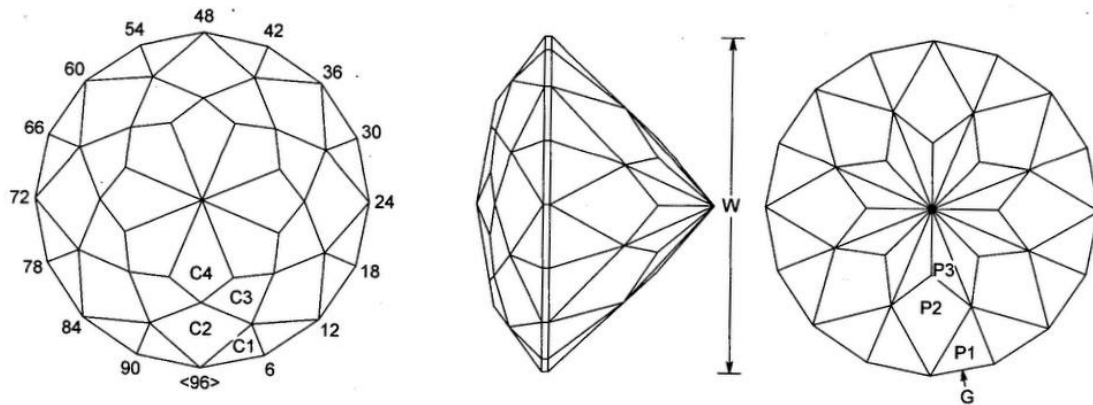

Park Lane Cut

Designed by Kel Smith
 Angles for R.I. = 1.540
 80 + 16 girdles = 96 facets
 8-fold, mirror-image symmetry
 96 index
 L/W = 1.000
 P/W = 0.493 C/W = 0.200
 Vol./W³ = 0.238

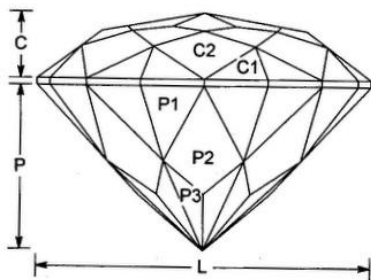

PAVILION

P1	51.00°	03-09-15-21-27-33-39-45-51-57-63-69-75-81-87-93	Cut to TCP
G	90.00°	03-09-15-21-27-33-39-45-51-57-63-69-75-81-87-93	Cut to size and level girdle
P2	47.00°	96-12-24-36-48-60-72-84	Cut to meet P1/G/P1
P3	41.00°	03-09-15-21-27-33-39-45-51-57-63-69-75-81-87-93	Cut to meet P1/P1/P2/P2 and meet at PCP

CROWN

C1	45.00°	03-09-15-21-27-33-39-45-51-57-63-69-75-81-87-93	Cut to set girdle width and level girdle
C2	37.00°	96-12-24-36-48-60-72-84	Cut to meet C1/G/G/C1
C3	22.00°	06-18-30-42-54-66-78-90	Cut to meet C1/C2/C2/C1
C4	10.00°	96-12-24-36-48-60-72-84	Cut to meet C3/C2/C3 and meet at PCP